

Electric Boilers

MINI ULTRA

Models from 6 kW to 12 kW : 208/240V single phase

INSTALLATION & OPERATING MANUAL



Your *MINI ULTRA* Electric Boiler has been carefully assembled and factory tested to provide years of trouble-free service. The following information and safety measures are provided to enable proper installation, operation, and maintenance of this product.

It is imperative that all persons who are expected to install, operate or adjust this boiler should read these instructions carefully.

Any questions regarding the operation, maintenance, service or warranty of this electric boiler should be directed to the supplier.

When all installation steps have been completed, insert this installation manual in its original envelope, and keep in a safe place (close to the boiler) for future reference.

Ratings & Specifications at 120/240** Vac/1ph (3 wires L1-N-L2):

MINI ULTRA					Cable*! 90C		Breaker! *
Model	Capacity KW/BTU at 240Vac**	Amps. ! Elements at 240Vac**	Electric Element(s) at 240Vac	Stages	Cu	Al	Amp.
MINI Ultra 6	6 / 20,470	25	2 x 3 KW	2	8	6	40
MINI Ultra 7.5	7.5/25,590	31	1X4.5+1X3K	2	8	6	40
MINI Ultra 9	9 / 30,710	37.5	2 x 4.5 KW	2	8	6	50
MINI Ultra 12	12 / 40,940	50	2 x 6 KW	2	6	6	70

! Add the amperage (Max. 5amp-1/6hp) of the circulating pump if it is connected directly to the boiler

* A higher capacity cable and breaker could be required. In all cases the local Electrical Code has priority.

** Can be connected to a 208Vac/1ph electrical supply. The resulting capacity will be of 75% of the nominal capacity at 240V and the amperage will be of 87%.

Dimensions

Connections		Overall dimensions	
Inlet/ heating return	3/4 " NPT Fem	Height	21-1/2 inches
Outlet/ heating supply	3/4 " NPT Fem	Width	9 inches
Pressure relief valve	3/4 " NPT Fem	Depth	9 inches
Drain valve	3/4 " NPT Fem	Weight	40 lbs.

Operating temp. range: 50°F (10C) to 190°F (88C). Maximum pressure : 30 psi (207kPa)

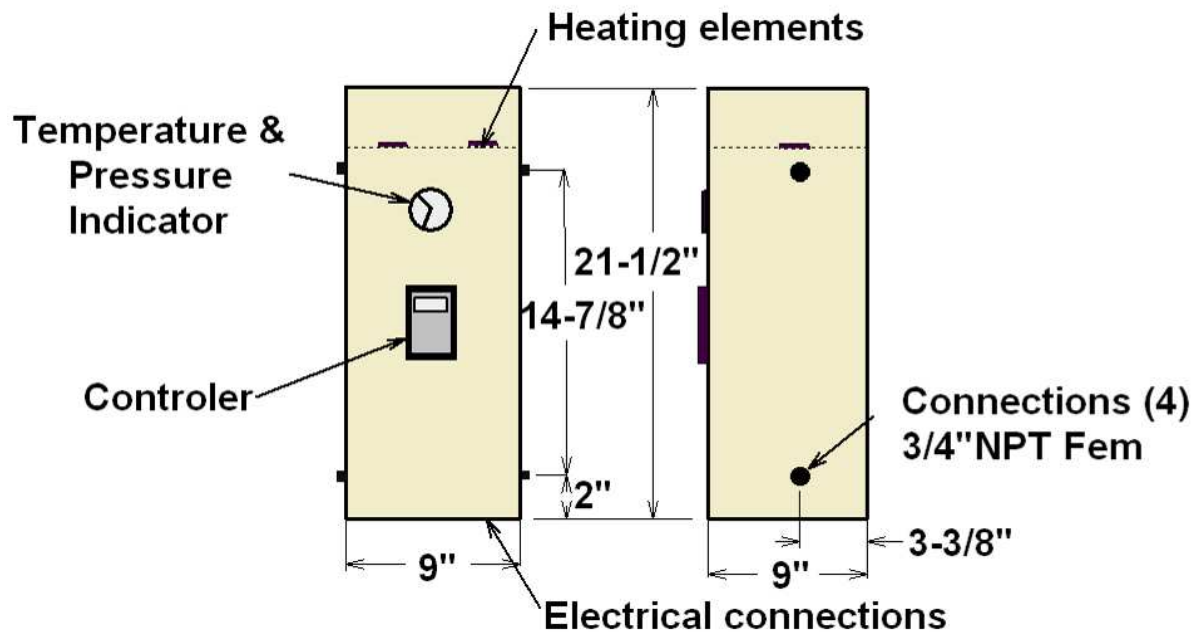

Figure 1.



General Safety Precautions

Be sure to read and understand the entire Installation & operation manual before attempting to install or to operate this water heater. Pay particular attention to the following General Safety Precautions. Failure to follow these warnings could cause property damage, bodily injury or death. Should you have any problems understanding the instructions in this manual, STOP, and get help from a qualified installer or technician.

INTRODUCTION

WARNING

These important safeguards and instruction appearing in this manual are not meant to cover all possible conditions and situations that may occur. It should be understood that common sense, caution and care are factors which cannot be built into every product. These factors must be supplied by the person(s) caring for and operating the unit.

LOCAL INSTALLATION REGULATIONS

This electric boiler must be installed in accordance with these instructions and in conformity with local codes, or in the absence of local codes, with the National Plumbing Code and the National Electric Code, current edition. In any case where instructions in this manual differ from local or national codes, the local or national codes take precedence.

SECURITY CONSIDERATIONS

All installations have a maximum design operating pressure limited to 30 psi (207kPa) by a safety relief valve.

Boiler operating temperature range is from 50°F(10C) and 190°F(88C). This boiler is designed **to be used only** in a hot water close circuit heating system.

A mix of water and propylene-glycol antifreeze specially formulated for heating system can be used up to a maximum concentration of 50%.

CHECK LIST

Please check the identification tag on the unit to make sure you have the right model.

List of components shipped with the unit :

- Pressure relief valve set at 30 PSI.
- Drain valve.
- Temperature & pressure indicator (Factory installed).
- Outdoor temperature sensor

SHIPMENT INSPECTION

Inspect the electric boiler for possible shipping damage. The manufacturer's responsibility ceases upon delivery of goods to the carrier in good condition. Consignee must file any claims for damage, shortage in shipments, or non-delivery immediately against carrier.

INSTALLATION

⚠ WARNING

The manufacturer's warranty does not cover any damage or defect caused by installation, or attachment, or use of any special attachment other than those authorized by the manufacturer into, onto, or in conjunction with the water heater. The use of such unauthorized devices may shorten the life of the boiler and may endanger life and property. The manufacturer disclaims any responsibility for such loss or injury resulting from the use of such unauthorized devices

LOCATION

The electric boiler should be installed in a clean, dry location. Long hot water lines should be insulated to conserve water and energy. The electric boiler and water lines should be protected from exposure to freezing temperature.

The electric boiler must be located or protected so as not to be subject to physical damage, for example, by moving vehicles, area flooding, etc.

⚠ CAUTION

The electric boiler should not be located in an area where leakage of the tank or water connections will result in damage to the adjacent area or to lower floors of the structure. When such areas cannot be avoided, a suitable drain pan or non-flammable catch pan, adequately drained, and must be installed under the boiler. The pan must be connected to a drain.

NOTE: Auxiliary catch pan **MUST** conform to local codes.

The boiler can be mounted directly on a wall with adequate screws. It needs to be properly leveled.

All models in alcoves. The ambient temperature must not exceed 90F (32C)

The electric boiler should not be located near an air vent blowing a corrosive atmosphere or high humidity. The limited warranty is void when the failure of the electric boiler is due to a corrosive atmosphere.

The choice of the mounting position of the boiler shall be made in relation with the required clearances shown below and the fact that the electric element compartment of the boiler needs clearance to allow their replacement.

°CLEARANCE

For adequate inspection and servicing the following minimum clearance is necessary:

Sides	4 in. /10cm
Electric elements side	14 in./35cm
Front side of the boiler	24 in./60cm
Back	0 in./0cm

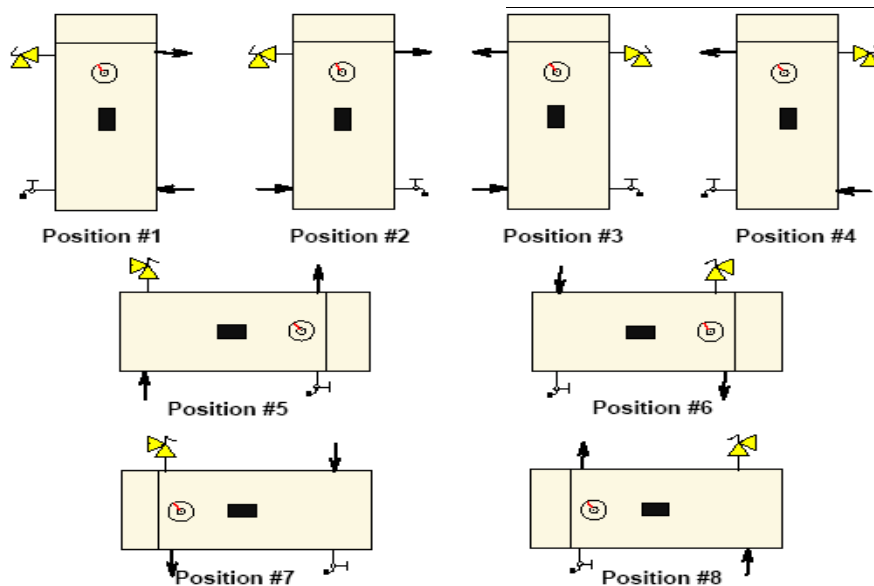

Fig. 2 Mounting position

BOILER WATER CONNECTIONS

Make sure you connect the accessories and the piping to the proper connection fittings as indicated at figure 2 above and according to the selected mounting position.

Figure 3 below shows typical connections of a MINI boiler to a radiant floor heating system. The location of the distribution system components may be different from what is represented.

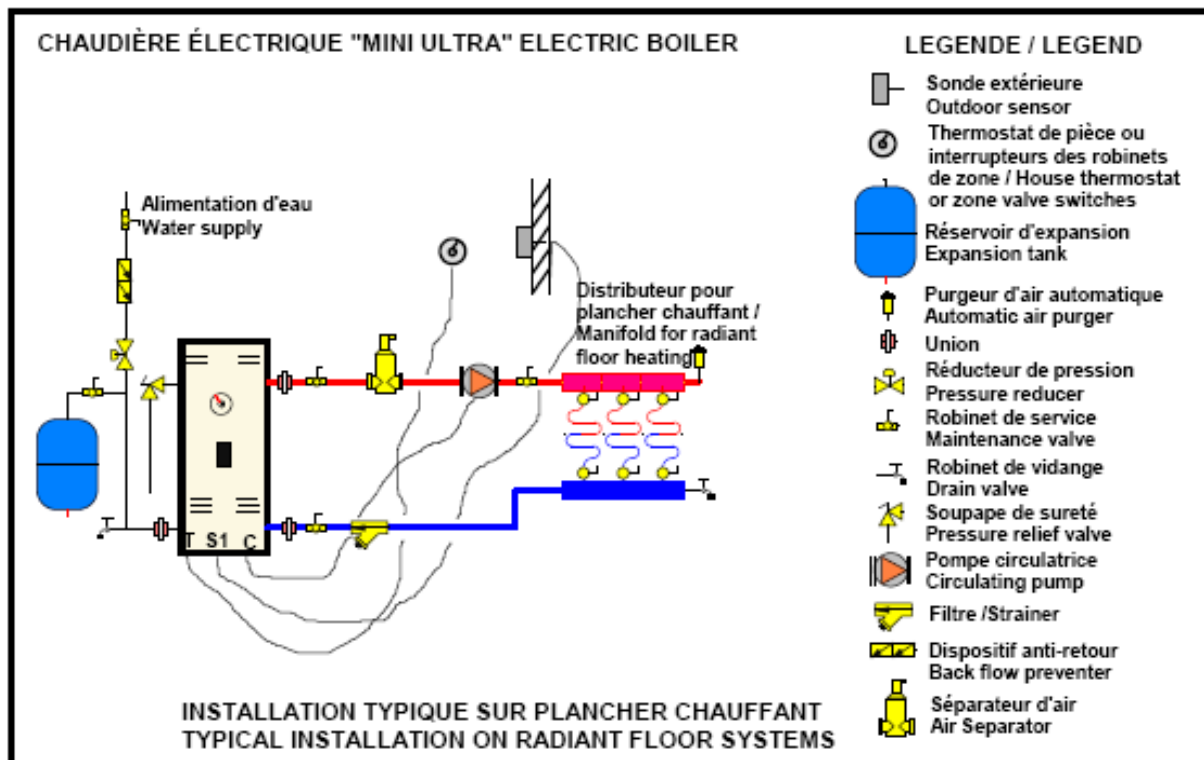

Figure 3 : Typical piping lay-out

Flow check valve

On heating systems having more than one pump, each pump will need to be equipped with a flow check valve either incorporated into the pump or separate.

Pressure relief valve

This component supplied with the unit must be installed directly to the boiler housing to the appropriate connection according to the mounting position.

Connect the outlet of the relief valve downward to a safe location in case of discharge.

The piping diameter used for the discharge piping shall not be smaller than that of the valve outlet.

No valve of any type, restriction or reducer coupling should be installed on the discharge line. Local codes shall govern the installation of relief valves.

Expansion tank

The expansion tank must be able to store the required volume of boiler water during maximum design operating temperature. The maximum allowable operating pressure is 30PSI (207kPa). Contact your plumbing supply house for assistance.

Water pressure feeder regulator

When a pressurized water supply is available in the building, a make-up systems consisting in a water pressure reducer generally set at 12psi (83kPa) and equipped with check valve satisfying local regulations must be installed between the boiler and the water supply system.

If the boiler is installed in a building that does not have a water supply and when the local plumbing codes allows, it is possible to simply manually pressurized the heating system equipped with an expansion tank to 10 (7kPa) to 28psi (193kPa) and

manually maintain a minimum pressure when required. Another possibility is to install a pressurized storage tank specially made for those applications that will inject on request an appropriate quantity of liquid to maintain an appropriate pressure on the heating system.

Air bleeder

Installation of manual or automatic air vents are required to eliminate all air from the boiler and the heating distribution system.

When the boiler is installed above the heating distribution system, an automatic air separator/eliminator must absolutely be installed at the outlet of the boiler in order to eliminate all possibilities of air buildup inside the boiler that would damage the heating elements.

Circulating pump

We recommend that the pump be installed at the outlet of the boiler with isolating valves as shown in figure 3.

The pump shall be selected such as to be able to supply adequate flow in relation to the heating distribution system on which it will be connected and the heating capacity of the boiler installed.

The table below will give you details on required water flow for distribution systems having to operate with a differential temperature of 10F and 20F between their inlet and outlet.

Model	Diff. 10F (usgpm)	Diff. 20F (usgpm)	Boilerpress.drop
MINI Ultra 6	4.0	2.0	Negligible
MINI Ultra 7.5	5.1	2.5	Negligible
MINI Ultra 9	6.0	3.0	Negligible
MINI Ultra 12	8.2	4.1	Negligible

The boiler has to be activated only upon a call for heat and when a pump will be working (no jumper allowed on TT terminals) a minimum water flow of 1usgpm is recommended.

Your heating wholesaler shall be in good position to recommend the appropriate model for your application.

The amperage drawn by the pump and other 120volts components shall not exceed 5 amps or 1/6HP.

Drain valve

Installed at the lowest point of the unit, it allows the unit to be drained for the eventual replacement of a defective component.

Strainer

This component is used to collect potential sediments coming from the distribution system and more particularly from systems made of steel piping and radiators. If such sediments accumulate at the bottom of the boiler it could be harmful to the heat transfer of the elements and generate premature failures.

ELECTRICAL CONNECTIONS:

Main boiler supply

Wiring must conform to the National Electrical Code and to state or local code requirements.

The electric boiler must be electrically grounded in accordance with local codes, or, in the absence of local codes, with the National Electrical Code.

Wiring must come from a 120/240 Volt (single phase, 60 Hz) "L1-L2-N" circuit protected by a properly sized breaker.

Wire gage (3 wires+ground) must be properly sized. Consult the boiler rating plate to select the proper breaker and wire gage.

The main terminal block of the boiler is suitable for #14 to #2 wires.

Supply cables can be made of Aluminum or Copper and be rated for 90C (194F).

If aluminum cables are used, it shall be of an adequate size (generally bigger) to meet the National electrical code.

Electrical supply of External accessories

The total 120vac consumption of the boiler and external accessories must not exceed 5A.

The maximum electrical consumption of 24vac external accessories connected to R&C terminals must not exceed 30Va. The available voltage at the boiler transformer must not drop below 24Vac.

Outdoor temperature sensor

If you want the target boiler temperature to modulate according to the outdoor temperature (when the outdoor temp. will get colder, the target temp. will get higher) , the supplied outdoor sensor will have to be connected to S1 S1 before turning the power on to the unit.

The installation of this sensor avoids the operation of the boiler when the outdoor temperature exceeds the selected value corresponding to the maximum temperature required for heating.

The sensor shall be connected to terminals **S1-S1** in the boiler using a two conductor cable 18ga.

Thermostat(s) and pump(s) connections:

Thermostats:

Use a low voltage 24Vac thermostat designed for central heating (not electric baseboards). Some thermostats are equipped with floor temperature sensor.

The purpose of the thermostat is to transmit an heat demand to the boiler. When this demand is received, the boiler will control the activation of the heating elements.

❑ Heating systems equipped with one thermostat and one pump:

With an 18 gauge cable, connect the room thermostat as follow:

Thermostat with 2 wires: Connect the two wires to the **R & W** boiler terminals.

Thermostat with 3 wires: Connect the **C/R/W** wires from the thermostat to corresponding terminals on the boiler

Using 14 gauge wires, connect the circulating pump directly to terminals **“P” and “P”** (120vac).

N.B. The amperage drawn by the pump must not exceed 5A-1/6HP.

❑ Multiple pumps zoning applications:

Components shall be connected in such a way that when a thermostat is calling for heat, only the corresponding pump be operated and an auxiliary contact X-X closes to give the signal of the heat demand to the boiler otherwise the elements will not be working.

To do so, you will need relays as illustrated below. Boiler terminals **PP-** will not be used.

N.B. Do not install a jumper between terminals **R** **W** of the boiler.

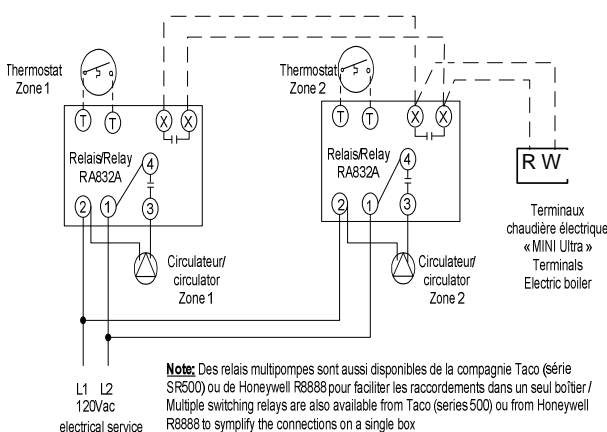

Fig.4: Multiple pumps electrical diagram.

Zoning with motorized valves :

Connect the low voltage thermostat to the zone valve. Components must be wired to ensure that only the zone valve corresponding to the zone calling for heat is actuated. When a zone valve opens, it generally closes a switch that is incorporated in it. Connect each switch to the **“R”** & **“W”** terminals in the boiler.

Connect the circulator to terminals **“P”** and **“P”** in the boiler.(max. 5A-1/6hp) . The electrical connections of the motorized zone valves shall be made according to the manufacturer's instructions.

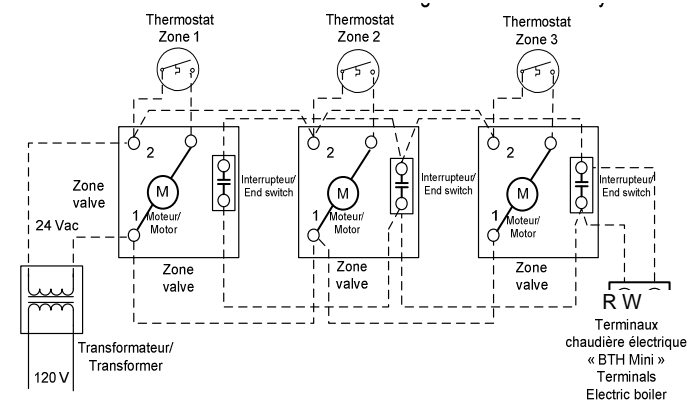

Fig. 5 Zone valves electrical diagram.

Diagramme électrique/ Wiring diagram MINI ULTRA SMART 6-9kW



Diagramme électrique/ Wiring diagram MINI ULTRA SMART 12kW



ADJUSTMENTS OF THE CONTROL MODULE

INTRODUCTION

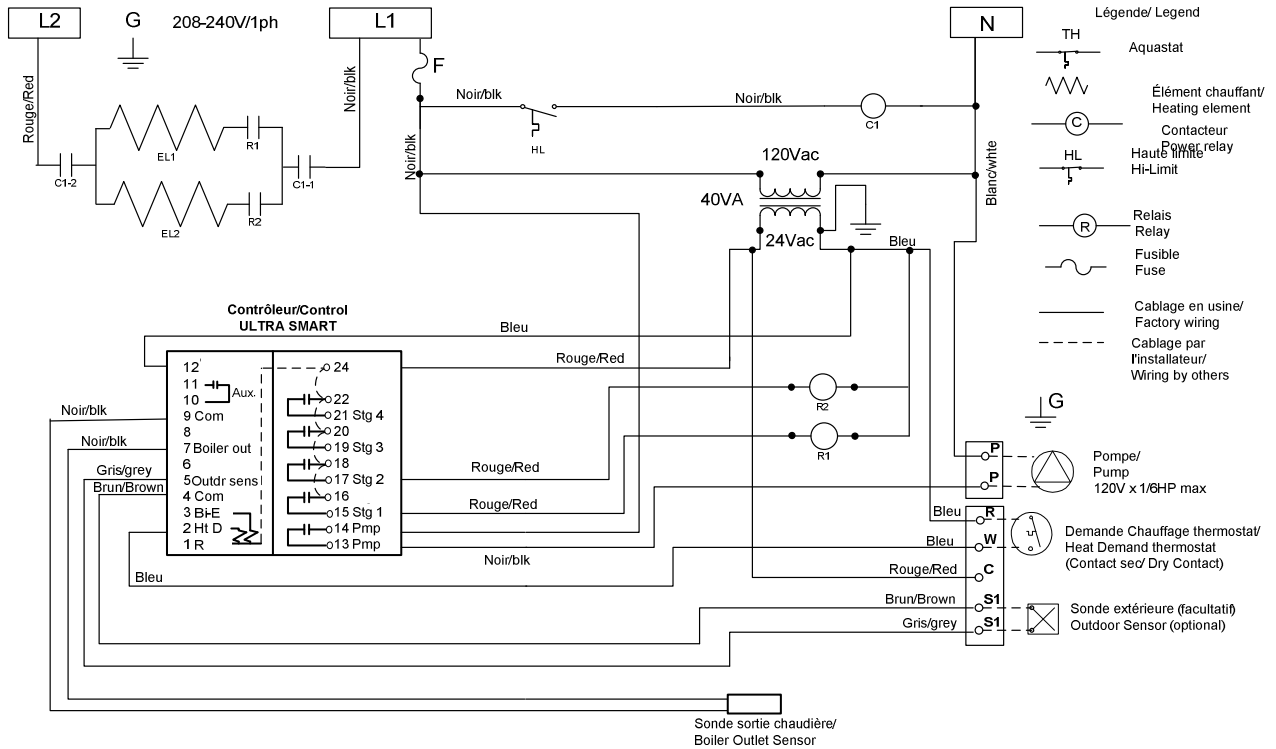
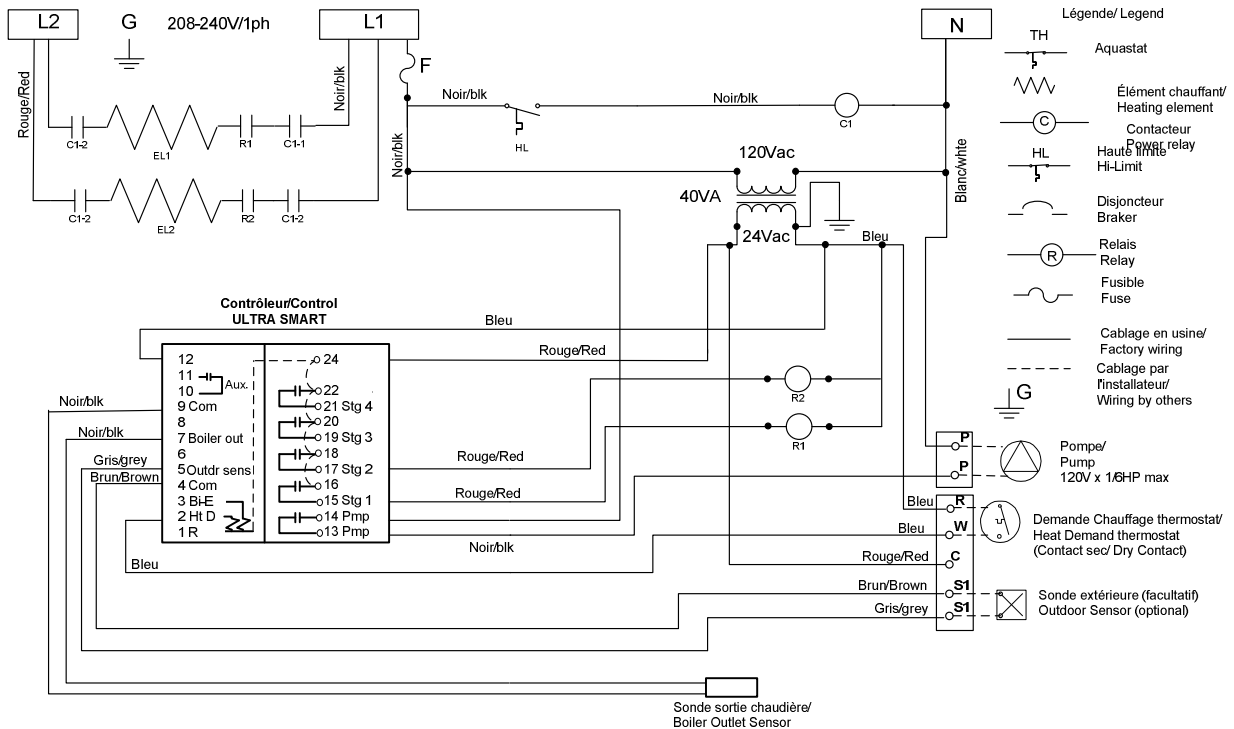
The MINI Ultra boiler is mainly designed to be installed on closed circuit applications where the water of the heating system flows directly from the boiler to the heating distribution system (Standard parallel Piping system)

Two operation modes are then offered:

- Fixed boiler temperature set point (the outdoor sensor shall not be installed)**

- Outdoor reset**

DISPLAYED INFORMATION

The electronic control uses an LCD display to make all adjustments and to visualize the operation of the system.

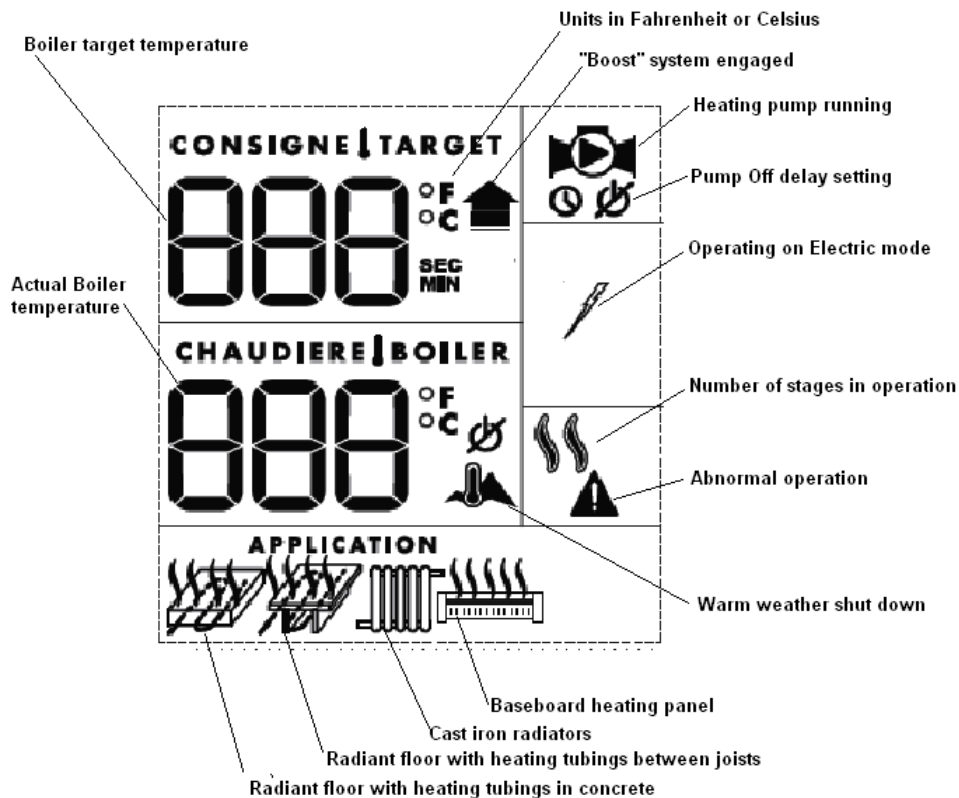

OPERATION OF THE INTERFACE

The controller uses four push buttons at the bottom of the display to select and adjust the parameters.

The button is used to access to the configuration menu and confirm a selection.

The buttons are used to select an item or adjust a value.

The button enables the illumination of the display under two different modes.

The default mode will enable the illumination of the display for a period of 10 sec. each time a button is pressed. If the is pushed, the light will be continuously illuminated. Just press the button to change the mode of activation.



OPERATION IN “FIXED BOILER TEMPERATURE SET POINT”

For installation where the boiler target temperature shall be maintained at a fixed temperature that will not vary in relation to the outdoor temperature, the sequence of operation will be as follow:

On a call for heat from the room thermostat, the circulating pump will start and the boiler will activate the number of stages required to get to and maintain the outlet temperature of the boiler near the selected target temperature. A rotation of the stages based on an equal time period of operation is provided.

N.B. The supplied outdoor temperature sensor shall not be connected before applying the electrical power to the unit

OPERATION WITH “OUTDOOR RESET”:

For installation where the boiler target temperature shall modulate in relation to the outdoor temperature; when the outdoor temperature gets colder, the boiler target temperature will increase.

On a call from the room thermostat, the circulating pump will start and the boiler will activate the number of stages required to get to and maintain the outlet boiler temperature near the target temperature established by the controller according to the outdoor temperature. A rotation of the stages based on an equal time period of operation is provided.

N.B. The supplied outdoor temperature sensor must be connected before applying the electrical power to the unit.

The boiler target temperature will be calculated by the controller in relation to the parameters selected in the menu



and the maximum target temperature required when the outdoor temperature will get to -10F (-23C). The “STD” curve corresponds to the default maximum temperature for a typical system and this value can be modified from the “MIN” to “MAX” value shown on the following tables.

The following tables show the values of the target temperature that will be obtained in relation to the outdoor temperature.

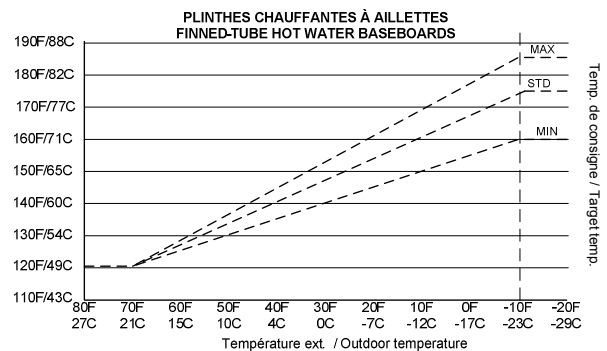
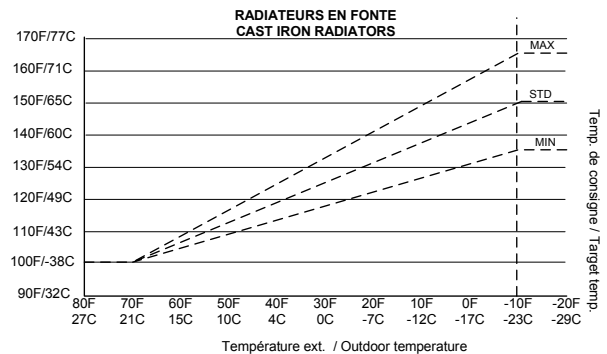
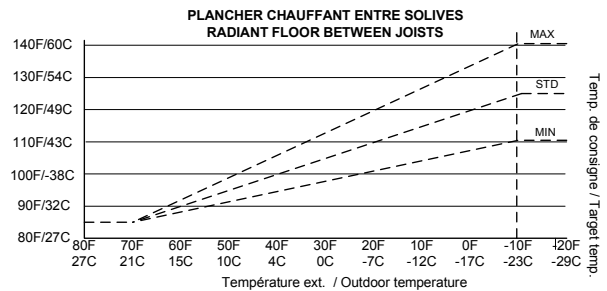
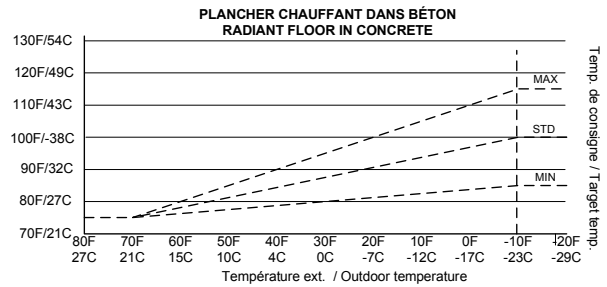

PURGE DELAY OF THE PUMP



The controller offers the possibility to stop the operation of the pump after an adjustable delay once the heat demand has been completed.

The following choices are offered:

-“OFF” The pump will stop immediately when the heat demand has been satisfied. This selection shall be selected on systems equipped with

motorised fast closing time zone valves with in order to prevent noise from water hammering.
-“15 sec to 60min” delay where the pump will be kept running to enable the pump to circulate water into the system to equilibrate the heat in all the building.
-“ON” The pump is in continuous operation.
Required on particular heating distribution systems.

AUTOMATIC HEATING SHUT DOWN



When the outdoor sensor is installed and that the unit then operates in the “outdoor reset” mode, the controller offers the user the possibility to automatically stop the boiler when the outdoor temperature reaches an adjustable value (0F (-17C) à 105F (40C). This characteristic is especially interesting on the following applications:

- Heating systems equipped with many thermostats where the user wants to prevent the operation of the unit if one of the thermostats has inadvertently been activated
- Heating systems where the owner supplies heat to a lodger
- Systems connected to a geothermic heat pump where we do not want the electric boiler to be

operating unless the outdoor temperature drops to a selected degree.

CONFIGURATION OF THE CONTROLLER







Since each type of heating distribution system is designed to operate at water temperatures that are particular to its operation, the proper configuration of the operating parameters of this particular system is important to maximize its performance.

In order to do this, the installer will access the configuration menu by pressing the  button for 2 sec. until the first menu appears. The selection of the item or value is made by pressing the  button and by pressing the  button to get to the next menu. See table 1 below to visualize the menu list that will gradually be displayed.

If the buttons remain untouched for a period of 10 sec., the controller will register the value of the selection made and return to the regular display position. It will also return to the regular display after reviewing all the operating parameters of the controller.



In case of a power failure, the parameters will be restored as they were established before the failure.

Table 1:

ITEM	DESCRIPTION	RANGE	DEFAULT
	Choose the units the user prefers to work with	F ⁰ or C ⁰	F ⁰
	Select the type of heating system on which the boiler will be installed.	-Radiant Floor in concrete -Radiant Floor between joists -Cast iron radiator Hot water baseboards	
CONSIGNE TARGET 	Adjust the maximum boiler target temperature required to adequately heat the building when the outdoor temperature is very cold.	-Radiant Floor in concrete 85à 105F -Radiant Floor between joists 110Fà140F -Cast iron radiator 135F à 165F -Baseboard 160F à 185F	100F 125F 150F 175F
	Select the purge period that the pump will be running once the heat demand is completed. Select OFF if the heat system is equipped with electric zone valves.	OFF 15 sec. to 60min. ON	30sec
	Select the outdoor temperature at which no heating of the building is required (the outdoor sensor has to be installed)	0F à 105F	75F

Note1: Once these parameters have been set, the controller will automatically return to its normal view but the user has the possibility to change the target temperature without having to go through the complete menus.

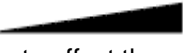

Adjustments of the target temperature by the user:

By pressing the    the end user has the possibility to offset the programmed

target temperature without going through the tool menus.

When the + or- button is pressed, the value "0" will appear and blink to show a "0" offset value from the original settings. When the + or-

buttons are pressed again the offset value will change up to a value of + -10F(5C) from the original setting made in the configuration menu. The new value will blink during 5 sec. and the display will then go back to the standard view and the new target temperature will be shown.

Afterward, when the   button will be pressed, it will show the value of the offset made previously and can be re-adjusted.

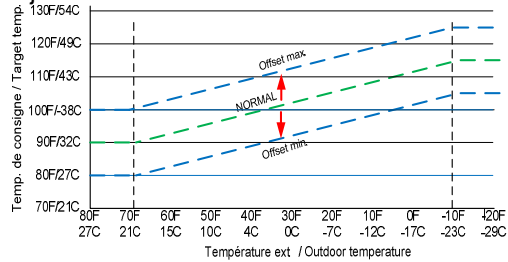



Boost system operation

The controller incorporates a unique feature that enables the target boiler temperature to automatically be increased when the building heat load increases but cannot be fulfilled with the actual boiler target temperature and consequently the room thermostat(s) cannot be satisfied within a pre-determined period.

Example:

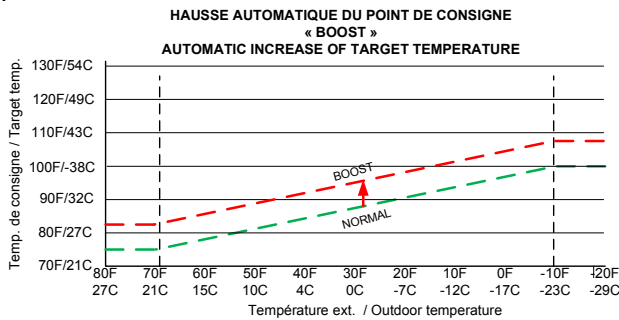
- Return to normal heat load after low demand periods occurring during sunny days.
- Long periods without heating which needs higher boiler temp. to recuperate.
- Return to normal room temperature after thermostat's "nights set back" program





The controller will engage the "Boost" program when the heat demand on terminals **W&R** has been maintained for a pre-determined period according to the type of selected application. Once this period has been reached, the "Boost"  icon will appear on the display and the boiler target temperature will start increasing very slowly over a pre-determined period and up to a pre-calculated maximum value until the heat demand applied on W&R terminals has been completed.

On a new heat demand, the previous boost period is forgotten and the boiler target gets back to its original setting

If the system is in "boost" most of the time, this means that the boiler target parameter established during "Setting procedure" would be too low for the heating system on which the unit is applied. This boiler target could simply be gradually increased by pressing the + button or by re-setting the operating parameters using the tool menus.

N.B. The boost program is a marvellous feature that works fine on applications where the number of room thermostats is in limited quantity otherwise it may happen that during very cold periods the heat demand from all the thermostats may not become satisfied.

If your application needs the boost program to be cancelled, you can do it by pressing the button  for 6 sec. and the display will show  icon and the two options ON or OFF will blink and can be selected using the + - button. The controller will register the selected option and return to normal operation if the buttons remains untouched for 5 sec. or if the  button is pressed.

START UP OPERATION



SAFETY PRECAUTIONS

Before operating this boiler, be sure to read and follow these instructions, as well as the warnings printed in this manual. Failure to do so can result in unsafe operation of the boiler resulting in property damage, bodily injury, or death. Should you have any problems reading, following or difficulty in understanding the instructions in this manual, STOP, and get help from a qualified person.

Do not turn on the boiler unless it is filled with water. Do not turn on the boiler if the cold water supply shut-off valve is closed.

Preparatory step

- ❑ Make sure that all the piping and electrical connections have been made.
- ❑ Fill the boiler and the heating system with water.
- ❑ Check for leaks.
- ❑ Check the pressure reading at the temperature and pressure indicator. It should be around 12psi.
- ❑ Turn On the electrical supply to the boiler with no heat demand from the thermostat(s).
- ❑ Completely eliminate all the air from the boiler and the distribution piping system. To do so, activate the circulating pump without the heating elements. If the pump is connected directly on **PP** terminals of the boiler, it can be activated by selecting "ON" in the configuration menu after having pressed  for 2 seconds.
- ❑ Adjust the UltraSmart boiler temperature controller as explained earlier and set the purge delay of the pump from On to its normal operation setting.
- ❑ Set the room thermostat ON to generate a heat demand. The pump shall start. The heating elements shall gradually come on and the boiler temperature will increase.

Start up & Inspection

- ❑ Measure the amperage value drawn by the unit. It shall be around the value indicated on the boiler  the plate.
- ❑ **Partially** close the isolating valve at the outlet of the boiler to reduce the water flow and consequently **slowly** increase the outlet temperature. The heating elements shall gradually stop as the temperature increases and gets near the target temperature.
- ❑ Lower the adjustment of the room thermostat(s), the heating elements shall stop and the pump shall stop after the delay set on the controller.
- ❑ Check the pressure reading on the gauge of the unit. It should not be higher than 28 psi when the distribution system will get to its maximum operating temperature.

N.B. On initial start up it may take a considerable amount of time before the water reaches the target temperature
Further adjustments may be necessary as you use your boiler and the space heating system.

MAINTENANCE

INTRODUCTION

Properly maintained, your boiler will provide years of dependable, trouble free service. It is recommended that a regular routine maintenance program be established and followed by the user. Components are subject to eventual failure that requires service. Failure to use the correct procedures or parts in these circumstances may make the unit unsafe or reduce the life of the boiler.

The owner should have the following inspection and maintenance procedures performed:

At all time

An immediate inspection shall be made if:

- ❑ An odor of melted plastic or overheated material is detected
- ❑ A leak coming from the unit or the heating system is observed

If a leak is detected at the outlet of the safety relief valve, it could be related to a problem with components installed on your heating distribution system. A quick correction is then required.

Do not plug the outlet of this valve if a dripping condition occurs.

Twice a year:

- ❑ Check for the proper operation of the automatic air purger(s) and eliminate air from the radiators.

Annually:

- ❑ It is recommended that a visual inspection be made on the electrical compartments of the boiler to check the water tightness of the gasket on the element flange and also check for any signs of overheating of the components and wires. Required corrections should be made as soon as possible.
Parts used for replacement should be the same as the original equipment.

WARNING

Make sure that the power on the unit has been turned off before opening the electrical compartments of the boiler.

- ❑ Close isolating valves and clean the strainer located on the heating return piping.
- ❑ Open the boiler drain valve to eliminate deposits that could have settled at the bottom of

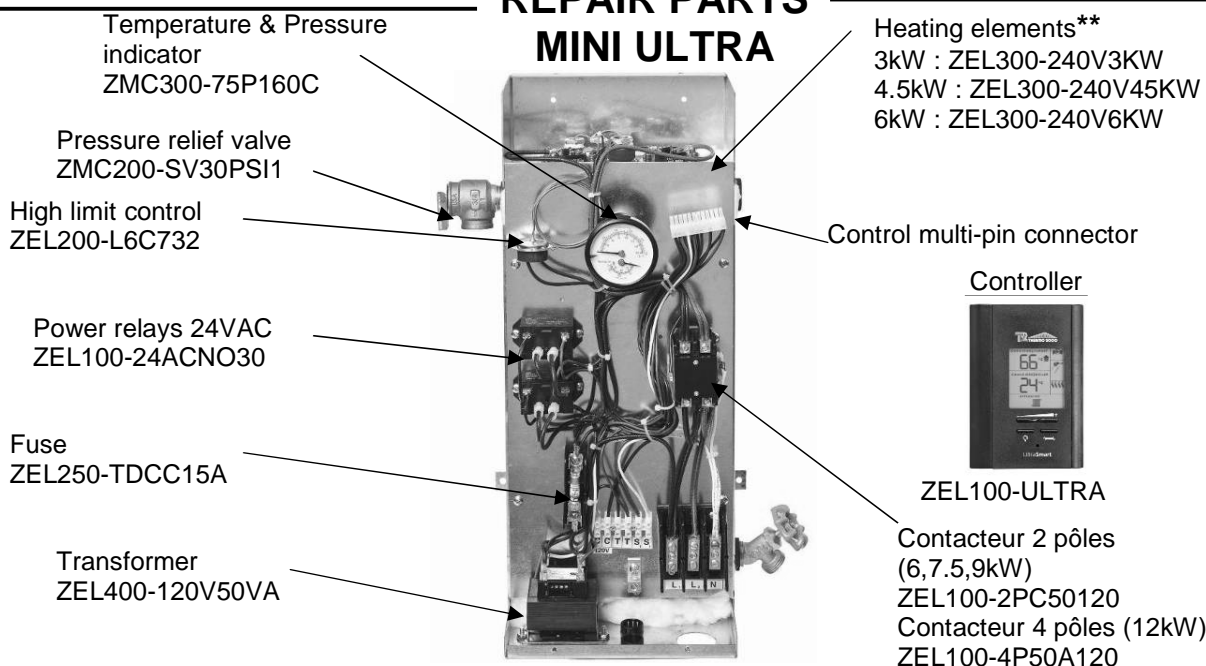

the boiler. Stop when water gets clear. If there is no flow or a very small flow, it could be due to a large accumulation of deposits at the bottom of the unit. If so, close the isolating valves at the inlet and outlet of the boiler, remove heating element(s) and clean the inside of the tank with a strong jet of water

REPAIR PARTS MINI ULTRA



****When replacing a heating element, make sure to install it in the same orientation it was installed at the factory.**

TROUBLE SHOOTING

PROBLEM	CAUSES	SOLUTION
The display shows --- in "TARGET TEMP"	<ul style="list-style-type: none"> -There is no heating demand -When the outdoor sensor  is used and the icon is shown, the outside temperature is above the boiler shut down setting. -The switch located on the back of the controller is set to "Bi-Energ" and the icon  is shown. 	<ul style="list-style-type: none"> -Generate a heat demand -Temporarily increase the value of this setting on the controller configuration. -Set the switch to "Elect"
The display shows "Er1" and the icon  is displayed.	The controller is not detecting the presence of the outdoor sensor.	<ul style="list-style-type: none"> -Make sure that the sensor cable connected to the unit is not in short or open circuit. Do not install a jumper between S1-S1 when the sensor is not required. -Check the resistance value (ohms) of the sensor. It should correspond to the value shown on the table below otherwise it should be replaced. Check for proper connection of the wires inside the boiler connected to S1S1 and at the controller terminals.
The display shows "Er2" and blinks	The controller is not detecting the presence of the boiler temperature sensor.	-Check the state of the sensor located in the immersion well located at the top of the elect. element compartment.

		--Check the resistance value (ohms) of the sensor. It should correspond to the value shown on the table below otherwise it should be replaced.
Stage 2 is ON but not Stage 1	There is no problem. A rotation of the stages is provided to allow an equal time of operation of the stages	
The boiler target temperature does not change when the outdoor temperature varies	The outdoor sensor has not been detected when the power has been applied to the unit.	Check the connection of the outdoor sensor to terminals S1S1. Turn OFF the power to the unit for 5 sec. and set it back ON.
The boiler water temperature at the outlet of the unit "BOILER T ⁰ " does not get to the "BOILER TARGET T ⁰ "	-The room thermostat is not in constant demand. -Some heating elements are defective -The total capacity of the boiler is expelled to the heating distribution system at this temperature.	-Adjust the thermostat anticipator (If available) to obtain longer operating cycles -Replace defective elements -If a boiler water temperature higher is required to satisfy the heat demands of the thermostats, a boiler having a larger capacity is required.
Boiler stays in demand even when the thermostat is not in demand. (Systems with more than one thermostat)	-On systems with electric zone valves, one or many end switches included in the valve is defective. -A jumper has been installed on terminals W&R of the boiler	-Change defective end switch. -Make appropriate connections as shown in fig.5
An overheated plastic odour is released from the boiler	Turn the power OFF to the boiler. Open the front and left side panel of the boiler. Check the components and electric wires for indications of overheating.	Replace overheated components and check supply voltage to the boiler.
Boiler safety valve is leaking	-Pressure reading at the indicator shows a pressure above 28psi -Pressure is below 28psi	-The pressure regulator on the distribution system is defective or the expansion tank is too small or defective. -Replace the safety valve

Temperature		Resistance	Temperature		Resistance	Temperature		Resistance	Temperature		Resistance
°F	°C	Ω	°F	°C	Ω	°F	°C	Ω	°F	°C	Ω
-50	-46	490,813	20	-7	46,218	90	32	7,334	160	71	1,689
-45	-43	405,710	25	-4	39,913	95	35	6,532	165	74	1,538
-40	-40	336,606	30	-1	34,558	100	38	5,828	170	77	1,403
-35	-37	280,279	35	2	29,996	105	41	5,210	175	79	1,281
-30	-34	234,196	40	4	26,099	110	43	4,665	180	82	1,172
-25	-32	196,358	45	7	22,763	115	46	4,184	185	85	1,073
-20	-29	165,180	50	10	19,900	120	49	3,760	190	88	983
-15	-26	139,402	55	13	17,436	125	52	3,383	195	91	903
-10	-23	118,018	60	16	15,311	130	54	3,050	200	93	829
-5	-21	100,221	65	18	13,474	135	57	2,754	205	96	763
0	-18	85,362	70	21	11,883	140	60	2,490	210	99	703
5	-15	72,918	75	24	10,501	145	63	2,255	215	102	648
10	-12	62,465	80	27	9,299	150	66	2,045	220	104	598
15	-9	53,658	85	29	8,250	155	68	1,857	225	107	553

Table 2: Sensors resistance value vs real temperature.

MINI ULTRA LIMITED WARRANTY

Warranty Coverage for Residential Installation.

Thermo 2000 Inc. hereby warrants to the original residential purchaser that the MINI ULTRA tank installed in a residential setting shall be free of leaks during normal use and service for a period of fifteen (15) years from the date of purchase as long as the original residential purchaser owns the home in which the unit was originally installed. Residential setting shall mean usage in a single-family dwelling in which the consumer resides on a permanent basis. Also, residential setting shall mean use in multiple family dwellings in which one (1) MINI ULTRA tank is to be used in only one (1) dwelling. In the event that a leak should develop and occur within this limited warranty period due to defective material or workmanship, such leak having been verified by an authorized company representative, Thermo 2000 inc. will repair or replace at our sole discretion the failed unit with the nearest comparable model at the time of replacement.

The original residential purchaser is responsible for all costs associated with the removal and reinstallation, shipping and handling to and from manufacturing plant. The replacement unit will be warranted for the remaining portion of the original Warranty.

Warranty Coverage for Commercial Installation.

Thermo 2000 Inc. warrants to the original purchaser that the MINI ULTRA tank installed in a commercial setting shall be free of leaks during normal use and service for a period of fifteen (15) years from the date of purchase.

Commercial setting shall mean use in other than residential setting stated above in the residential setting definition. In the event that a leak should develop and occur within this limited warranty period due to defective material or workmanship, such leak having been verified by an authorized company representative, Thermo 2000 inc. will repair or replace at our sole discretion the failed unit with the nearest comparable model at the time of replacement.

The original purchaser is responsible for all costs associated with the removal and reinstallation, shipping and handling to and from Manufacturer. The replacement unit will be warranted for the remaining portion of the original Warranty.

Limited two years warranty on all MINI ULTRA components & parts

All other MINI ULTRA components & parts are warranted for a period of two (2) years against defects due to defective material or workmanship. The original purchaser is responsible for all costs associated with the removal and reinstallation, shipping and handling to and from Manufacturer. The components, repaired or replaced are warranted for the residual period of the initial warranty on the unit.

Exclusions

This warranty is void and shall not apply if:

1. Defects or malfunctions resulting from installation, repair, maintenance and/or usage that are not done in conformity with the manufacturer's installation manual; or
2. Defects or malfunctions resulting from installation, maintenance, or repair that are not done in accordance with regulations in force; or
3. Defects or malfunctions resulting from improper installation, maintenance or repair done carelessly or resulting from consumer damage (improper maintenance, misuse, abuse, accident or alteration); or
4. Installation in which a relief valve (pressure) is not installed or if it is not functioning properly, or when it is not connected to a drain to avoid damage to the property; or
5. Installation in which liquid circulating in the tank does not remain in closed circuit or installation in which piping is leaking; or
6. A polybutylene pipe or radiant panel installation without an oxygen absorption barrier is used; or
7. Installation where the acidity of water is not within the normal Environmental Protection Agency (EPA) (between pH 6.5 – 8.5) guidelines or the domestic water contains abnormal levels of particulate matter or water exceeding 10.5 gpg; or
8. Your home contains any type of water softener system and the unit is not installed and maintained in accordance with the manufacturer specifications; or
9. The MINI ULTRA unit has been subjected to non authorized modifications; or
10. Defects or malfunction resulting of storing or handling done elsewhere than Thermo 2000's manufacturing plant; or
11. Units on which the serial number is removed or obliterated.

Limitations

Thermo 2000 shall not be responsible for any damage, loss, and inconvenience of any nature whatsoever, directly or indirectly, relating to the breakdown or malfunction of the unit. This warranty limits its beneficiary's rights. Nevertheless, the beneficiary may have other rights, which vary from state to state.

This warranty replaces any other expressed or implicit warranty and constitutes the sole obligation of Thermo 2000 towards the consumer. The warranty does not cover cost of removal, reinstallation or shipping to repair or replace the unit, nor administration fees incurred by the original consumer purchaser.

Thermo 2000 reserves its rights to make changes in the details of design, construction, or material, as in its judgment constitute an improvement of former practices.

This warranty is valid only for installations made within the territorial limits of Canada and the United States.

Warranty service procedure

Only authorized MINI ULTRA dealers are permitted to perform warranty obligations. The owner or its contractor must provide Thermo 2000's head office or authorized depot with the defective unit together with the following information: MINI ULTRA model and serial number, copy of the original sales receipt and owner's identification certificate.



THERMO 2000 INC.

500, 9e Avenue, Richmond (Qc) Canada J0B 2H0
phone: (819) 826-5613 Fax: (819) 826-6370
www.thermo2000.com