

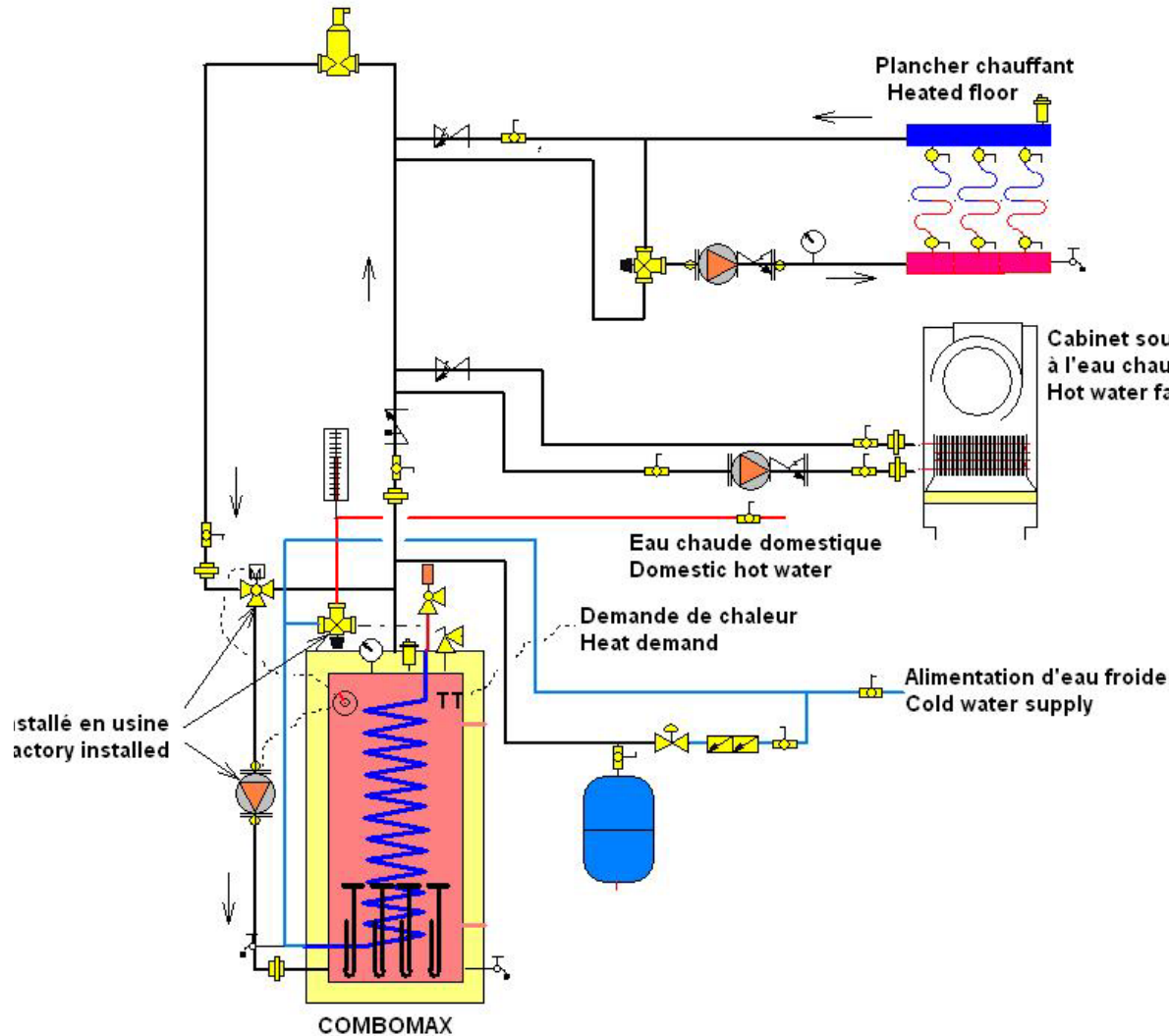











**"COMBOMAX" SUR SYSTÈMES DE CHAUFFAGE MULTIPLES**  
**"COMBOMAX" ON MULTIPLE HEATING SYSTEMS**



**LÉGENDE / LEGEND**

-  Réducteur de pression  
Pressure reducer
-  Clapet anti retour  
Check valve
-  Vanne de mélange thermostatique  
Thermostatic mixing valve
-  Éliminateur d'air automatique  
Automatic air vent
-  Pompe circulatrice  
Circulating pump
-  Pompe & anti-retour  
Pump and check valve
-  Vanne motorisée trois voies pour priorité eau domestique  
Three way valve for DHW priority
-  Réservoir d'expansion  
Expansion tank
-  Soupape Temp. & Pression  
Temp. & Pressure relief valve

L'installateur est responsable de l'adaptation de ces schémas d'installation en fonction de l'application et des normes en vigueur.  
 The person who installs this machine is responsible for adapting this diagram according to the norms in place.