

# ***TurboMax***<sup>®</sup>

## ***Instantaneous Indirect Water Heater***

### **USE & CARE MANUAL**

WITH INSTALLATION INSTRUCTIONS FOR THE CONTRACTOR



Your TurboMax<sup>®</sup> *Instantaneous Indirect Water Heater* has been carefully assembled and factory tested to provide years of trouble-free service. In order to ensure the service intended, the following information is provided to enable proper installation, operation, safety precautions and maintenance of this product.

It is imperative that all persons who are expected to install, operate or adjust this water heater read the instructions carefully so that they may understand how to do so.

Any questions regarding the operation, maintenance, service or warranty of this water heater should be directed to the entity from whom it was purchased.

When all installation steps have been completed, replace this installation manual in its original envelope, and keep in a safe place for future reference.

*Note: Copyright 2005. Thermo 2000 Inc. All rights reserved. TurboMax<sup>®</sup> is a registered trademark of Thermo 2000 Inc. Thermo 2000 reserves the right to modify at any time and without notice colors, components, materials, specifications or model described in or shown in this document.*

---

## TURBOMAX<sup>®</sup> Specifications

---

The indirect water heater shall be a TurboMax<sup>®</sup>, model \_\_\_\_\_ as manufactured by THERMO 2000 Inc. For the 80A and 120A models, the complete unit will meet the requirements of ASME Boiler and Pressure Vessel Code, Section VIII, div.1. The water heater heat exchanger shall be equipped with copper piping in the form of parallel helicoidal lines having a maximum operating pressure of 200 psi for the 120A200 model, 125 psi for the 120A125 and 150 psi for the others. All copper components and assembly will meet the low lead requirements for potable plumbing products and shall adhere to the NSF 61 standard (International Standard Drinking Water Systems Components Health Effects). The hot water heater shall have a patented steel injector through which the boiler water fluid enters the top of the tank and a steel collector through which the boiler water circuit fluid exits at the bottom of the tank. The tank shall be made of high-carbon steel. All joints shall be arc-welded using the MIG/argon process. The tank shall have a maximum operating pressure of 200 psi for the 120A200 model, 125 psi for the 120A125 and 150 psi for the others. The tank shall be encased in a polyurethane insulation limiting thermal loss to ½ °F per hour. The outer steel jacket shall be painted with baked epoxy. The water heater shall have a temperature controller (aquastat) that makes contact when the temperature falls below the tank's water temperature set point minus an adjustable differential and breaks contact when the temperature rises over the set point (100 °F to 220 °F). The tank shall have a ¾" drain (ball) valve made of brass, which have a maximum working pressure of 200 psi. Three adjustable feet support the water heater for leveling. The water heater shall be shipped from the factory with an ASME rated pressure relief valve set at 30psi (50 psi on models 80A, 120 and 120A) protecting the tank, a thermometer/pressure gauge, and an automatic air vent (Unless indicated otherwise). The water heater shall be backed by a 15-year warranty on residential applications and 10 years on commercial applications (consult the terms of the warranty included at the end of the instruction manual shipped with the water heater).

# Technical data

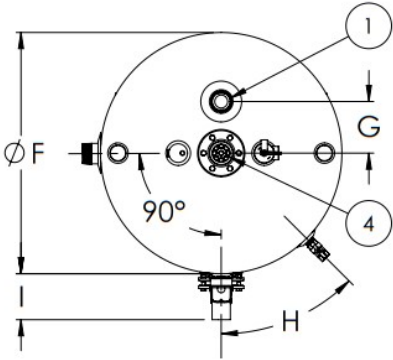
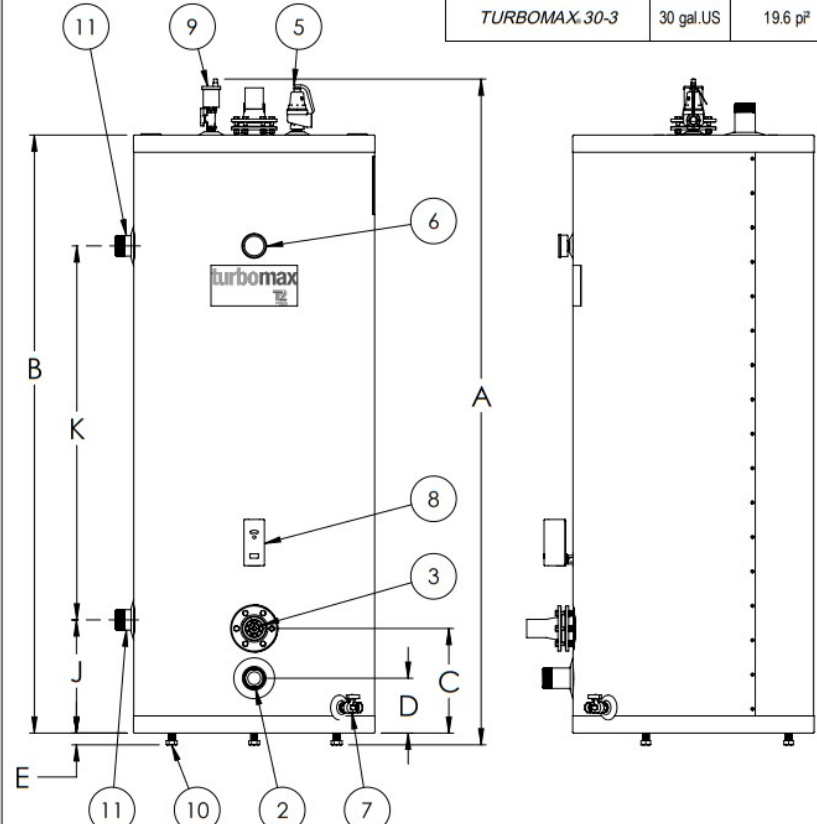
SHOP DRAWING	<b>TURBOMAX</b> ® Indirect water heater	THERMO 2000 inc.									
	TECHNICAL DATA										
	Models	Tank Volume	Heat transfer area (sq. ft.)	Domestic water connection	Boiler + TXT connection	Weight equipment	Shipping weight				
	<i>TURBOMAX 120-9A-200</i>	120 gal.US	58.9 pi²	2-1/2" Cuivre M	2" NPT M	540 lbs	590 lbs				
	<i>TURBOMAX 120-9A-125</i>	120 gal.US	58.9 pi²	2-1/2" Cuivre M	2" NPT M	450 lbs	500 lbs				
	<i>TURBOMAX 120-9</i>	119 gal.US	58.9 pi²	2" Cuivre M	2" NPT M	430 lbs	480 lbs				
	<i>TURBOMAX 80-5A-150</i>	80 gal.US	32.7 pi²	2" Cuivre M	1-1/2" NPT M	317 lbs	362 lbs				
	<i>TURBOMAX 80-5</i>	80 gal.US	32.7 pi²	1-1/2" Cuivre M	1-1/2" NPT M	308 lbs	353 lbs				
	<i>TURBOMAX 50-5</i>	50 gal.US	32.7 pi²	1-1/2" Cuivre M	1-1/4" NPT M	230 lbs	268 lbs				
	<i>TURBOMAX 50-3</i>	50 gal.US	19.6 pi²	1-1/4" Cuivre M	1-1/4" NPT M	212 lbs	250 lbs				
	<i>TURBOMAX 30-3</i>	30 gal.US	19.6 pi²	1-1/4" Cuivre M	1-1/4" NPT M	170 lbs	205 lbs				
	COMPONENT IDENTIFICATION										
	<ol style="list-style-type: none"> <li>1 Boiler Water Supply (Inlet)</li> <li>2 Boiler Water Return (Outlet)</li> <li>3 Domestic Water inlet</li> <li>4 Domestic Water outlet</li> <li>5 Pressure relief valve 3/4NPTF</li> <li>6 Temp. &amp; Press. indicator 1/2NPTM</li> <li>7 Tank drain valve 3/4NPTF</li> <li>8 Temperature control</li> <li>9 Automatic air vent 1/2NPTM</li> <li>10 Adjustable leg</li> <li>11 Extra Tappings "TXT "</li> </ol>										
DIMENSIONS											
MODELS	A	B	C	D	E	F	G	H	I	J	K
	in.	in.	in.	in.	in.	in.	in.	degrees	in.	in.	in.
<b>TURBOMAX 120</b>	77 7/16	69 9/16	12 1/8	6 5/16	1 1/2	28 1/16	6	45	5 3/8	13 1/8	43 1/2
<b>TURBOMAX 80</b>	75 3/8	67 5/8	11 1/8	5 5/16	1 1/2	24 1/16	6	45	5 3/8	12 1/8	43 1/2
<b>TURBOMAX 50</b>	60 11/16	52 13/16	11 13/32	7 13/32	1 1/2	22 1/16	4	45	5 1/4	7 13/32	38
<b>TURBOMAX 30</b>	59 11/16	51 5/8	10 13/16	6 13/16	1 1/2	18 1/16	4	45	4 1/4	6 13/16	38



## General Safety Precautions

Be sure to read and understand the entire Use & Care Manual before attempting to install or operate this water heater. Pay particular attention to the following General Safety Precautions. Failure to follow these warnings could cause property damage, bodily injury or death. Should you have any problems understanding the instructions in this manual, STOP, and get help from a qualified installer or technician.

To meet commercial water use needs, the aquastat on this water heater is adjustable up to 220°F. However, water temperatures over 125°F can cause severe burns instantly or death from scalds. 125°F is the preferred starting point for setting the control to supply general-purpose hot water.

Safety and energy conservation are factors to be considered when setting the water temperature on the aquastat. The most energy efficient operation will result when the temperature setting is the lowest that satisfied the needs consistent with the application.

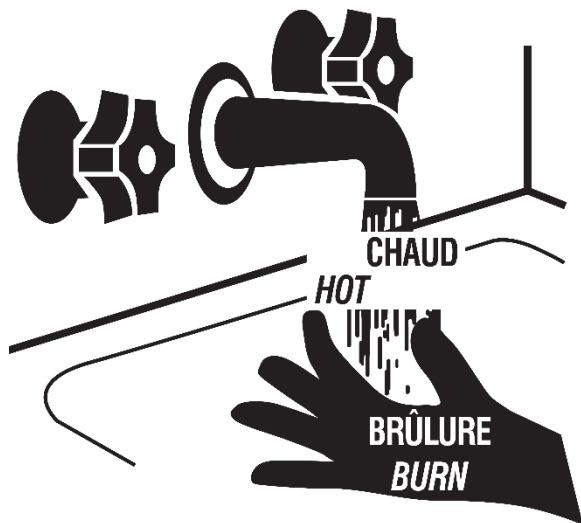

### DANGER

Water temperature above 125°F/52°C can cause severe burns or death from scalds. Children, disabled and elderly are at highest risk of being scalded.

For that reason, a certified ASSE1017 mixing valve for reducing the domestic hot water must be installed on the distribution piping.

The manufacturer installation instructions and the applicable local codes must be respected.

Maximum water temperature occurs just after burner or the energy source has shut off. To find

hot water temperature being delivered, turn on a hot water faucet and place a thermometer in the hot water stream and read the thermometer.

The following chart details the relationship of water temperature and time with regard to scald injury and may be used as a guide in determining the safest water temperature for your applications.

TIME VS TEMPERATURE RELATIONSHIPS IN SCALDS	
Temperature	Time to Produce Serious Burn
120°F	More than 5 minutes
125°F	1-1/2 to 2 minutes
130°F	About 30 seconds
135°F	About 10 Seconds
140°F	Less than 5 seconds
145°F	Less than 3 seconds
150°F	About 1-1/2 seconds
155°F	About 1 second

Table courtesy of Shriners Burn Institute

### DANGER

There is a Hot Water Scald Potential if the aquastat is set too high. When this water heater is supplying general purpose hot water requirements for use by individuals, a thermostatically controlled mixing valve for reducing point-of-use water temperature is recommended to reduce the risk of scald injury. Contact a licensed plumber or local plumbing authority for further information.

---

## Introduction

---

### WARNING

**The important safeguards and instructions appearing in this manual are not meant to cover all possible conditions and situations that may occur. It should be understood that common sense, caution and care are factors, which cannot be built into every product. These factors must be supplied by the person(s) caring for and operating the unit.**

### LOCAL INSTALLATION REGULATIONS

This water heater must be installed in accordance with these instructions and must conform to local, or in the absence of local codes, with the current edition of the National Plumbing Code and the National Electric Code. In any case where instructions in this manual differ from local or national codes, the local or national codes take precedence.

### DECISIONS REQUIRED BEFORE INSTALLATION

The tank of the TurboMax<sup>®</sup> water heater (boiler water) is factory shipped by default with a 30psi pressure relief valve (50 psi on models 80A, 120 and 120A). If the water application requires a higher operating pressure and if local jurisdictions permit it, this valve can be changed to a higher pressure rated valve that is lower than the rated maximum pressure of the tank. For installations used to provide hot water for domestic use, the tank pressure must always remain lower than the pressure of the domestic water supply especially on applications where a potentially toxic heat transfer solution is used. If the safety valve is changed, it is also advised to check if the manometer is still within normal operating range and change it if necessary.

In some jurisdictions the boiler's operating pressure must be limited to 30 psi (207 kPa) by a safety relief valve. When a higher operating pressure level is needed, select a boiler which is certified to operate at the required pressure. The boiler's output rating must be within the heater's recommended sizing guide specifications. Too high an output rating may cause a boiler short cycling condition. Where the boiler's output is used to supply space heating and domestic water heating, two options are available when wiring the controls. The first option uses a priority relay. When the aquastat of the water heater calls for

heat, the relay shuts off the space heating zones, giving priority to producing domestic hot water. Any demand for space heating is postponed until the water heater has reached a preset level. This delay in supplying the space heating zones is usually not noticed by those occupying the living space. The water heater gets adequate hot water flow from the boiler to maintain the full rated delivery of domestic hot water.

In the second option, the water heater will be supplied as just another heating zone. This means that if all space heating zones call for hot boiler water at the same time, the water heater may not be supplied with enough hot boiler water to "recover" adequately. The delivery of domestic hot water will be diminished. This is not a problem when the boiler output is sized adequately for both loads.

The flow of hot boiler water to the water heater can be controlled with either a pump or a motorized valve. If a zone valve is to be used, the space heating system circulator must have an adequate flow rate to allow proper heat transfer of BTUs from the hot boiler water stored in the tank to the domestic water flowing inside the water heater's heat exchanger. Be sure the space heating zone valve chosen has maximum pressure drop to insure proper boiler water flow to the heater. The recommended way to provide adequate boiler water flow through the water heater is to use a separate dedicated circulator. This option may be used even though the heating system utilizes zone valves.

### CAUTION

**The heat transfer medium must be water or other non-toxic fluid having a toxicity rating or class of 1, as listed in Clinical Toxicology of Commercial Products, 5<sup>th</sup> edition**

### LOCATION

The water heater should be installed vertically in a clean, dry location as close as practical to the boiler or the heat source. Long hot water lines should be insulated to conserve water and energy. The water heater and water lines should be protected from exposure to freezing temperatures. Use the adjustable feet to level the unit. It must be located or protected so it is not subject to physical damage, for example, by moving vehicles, area flooding, etc.

All models can be installed on combustible floors and in alcoves. Minimum clearance from combustible construction is 0 inches on all sides. A minimum 3 inch clearance on top, both sides and in the rear and a minimum 24 inch clearance in front and on top should be available for adequate inspection and servicing.

**⚠ CAUTION**

The water heater should not be located in an area where leakage from the tank or water connections will result in damage to the adjacent area or to lower floors of the structure. When such areas cannot be avoided, a suitable drain pan or non-flammable catch pan, adequately drained, must be installed under the water heater. The pan must be connected to a drain.

**NOTE: Auxiliary catch pan MUST conform to local codes.**

Catch pan or drain pan kits made of metal are available in 16”, 19”, 22”, 24” and 26-1/2” diameters from the distributor or store where the water heater was purchased.

**RESTAURANTS**

If the water heater is to be installed in a restaurant or other location where the floor is frequently cleaned, it must be elevated to provide at least 6 inches of clearance from the floor to comply with NSF International recommendations. A factory-designed leg extension kit is available for this purpose from the distributor or store where the water heater was purchased.

**CORROSIVE ATMOSPHERES**

The heater should not be located near an air supply containing halogenated hydrocarbons or high humidity. For example, The air in beauty salons, dry cleaning establishments, photo processing labs and storage areas for liquid and powder bleaches or swimming pool chemicals often contains such hydrocarbons.

The limited warranty is voided when failure of the water heater is due to a corrosive atmosphere.

TurboMax® water heaters designed for corrosive atmospheres are available from the distributor or store where the water heater was purchased.

**Check List of Mechanical Components for Proper Installation**

NON-PRIORITY SYSTEM	PRIORITY SYSTEM
<p><b>A) If separate circulator for each zone</b></p> <ul style="list-style-type: none"> <li>• 1 circulator per zone</li> <li>• 1 flow check per zone</li> </ul>	<p><b>A) If separate circulator for each zone</b></p> <ul style="list-style-type: none"> <li>• 1 circulator per zone</li> <li>• 1 flow check</li> </ul>
<p><b>B) If only one circulator used by the heating system</b></p> <ul style="list-style-type: none"> <li>• 1 zone valve per zone</li> </ul>	<p><b>B) If only one circulator used by the heating system</b></p> <ul style="list-style-type: none"> <li>• 1 – 3 way zone valve</li> </ul>
<p><b>C) Common Components:</b></p> <ul style="list-style-type: none"> <li>• 4 x unions</li> <li>• 4 x ball valves minimum</li> <li>• 1 x vacuum breaker (if required)</li> <li>• 1 x temperature &amp; pressure relief valve with probe of sufficient length.</li> <li>• 1 x thermostatic mixing valve</li> <li>• copper pipe &amp; copper pipe fittings</li> <li>• steel pipe &amp; steel pipe fittings</li> </ul>	<ul style="list-style-type: none"> <li>• 1 x potable water expansion tank if necessary. See the “Domestic water connections” section.</li> <li>• 1 x pressure reducing valve (boiler water)</li> <li>• 1 x pneumatic expansion tank</li> <li>• 2 x automatic air vents at least.</li> <li>• Switching relays or zone controller</li> <li>• And any other necessary components.</li> </ul>



## Included components

The water heater will be shipped from the factory with the following components in a box:



**Ball valve 1/2 po**  
ZMC200-BVP12NPT

**Ball valve 3/4 po**  
ZMC200-BVP34NPT

**Air vent**  
ZMC600-AV1/2

**\*Safety valve**  
ZMC200-SV30PSI2  
ZMC200-SV50PSI2  
ZMC200-SV50PSI3

**Adjustable Aquastat**  
ZEL200-AQAJUSDM  
(separate box)

**2 x Caps**  
**(Depends on model)**  
ZFT380-CAP11/4  
ZFT380-CAP11/2  
ZFT380-CAP2

**Pressure/  
Temperature  
gauge**  
ZMC300-75P160C2  
ZMC300-200P160C

\*Please refer to the section entitled *Replacement Parts List* (p. 30) for more information about which parts a certain model uses. These components must all be installed except for the caps, that are there to be used as needed. Two things must be respected during the installation of these accessories. All accessories must be installed with an appropriate sealing compound such as teflon tape. After applying the sealing compound, the part should be first tightened by hand and then tightened around two more turns with the proper tool.

---

## Installation

---

### WARNING

**The manufacturer's warranty does not cover any damage or defect caused by installation or attachment or use of any special attachment other than those authorized by the manufacturer into, onto, or in conjunction with the water heater. The use of such unauthorized devices may shorten the life of the water heater and may endanger life and property. The manufacturer disclaims any responsibility for such loss or injury resulting from the use of such unauthorized devices**

### INSPECT SHIPMENT

Inspect the water heater for possible shipping damage. The manufacturer's responsibility ceases upon delivery of goods to the carrier in good condition. Consignee must file any claims for damage, shortage in shipments, or non-delivery immediately against carrier.

### DOMESTIC WATER CONNECTIONS

This water heater may be connected individually, in multiples with others, or with an external hot water storage tank. If two TurboMax<sup>®</sup> or more are installed, the piping method to be used to connect the TurboMax<sup>®</sup> in parallel should be "reverse-return piping", so domestic water flow rate through each TurboMax<sup>®</sup> is equal.

The HOT WATER OUTLET and the COLD WATER INLET connections are clearly marked. Inlet water connections (COLD WATER INLET) are to be made to the copper pipe (sweat connection) at the bottom of the heater. Outlet water connections (HOT WATER OUTLET) are to be made to the copper pipe (sweat connection) at the top of the heater.

The installation of copper unions or copper alloy unions is recommended on the HOT and COLD water lines, so that the water heater may be easily disconnected for servicing if necessary.

Dielectric unions are required for protection of the water heater if dissimilar pipe material like galvanized pipe is used.

Install shutoff (ball) valves for servicing convenience.

Use only clean copper or approved plastic pipe for water connections. Local codes or regulations shall govern the exact type of material to be used.

To minimize heat loss during non-draw periods, a heat trap formed from piping can be used. Insulate all pipes containing hot water, especially in unheated areas.

Cap or plug unused connections. If the water heater is replacing a tankless coil in the boiler, do not cap tube outlets in the tankless coil after disconnecting from plumbing.

Thermometer(s) should be installed to indicate the temperature of the water at or near the outlet of the water heater and storage tank(s), if provided.

### EXPANSION TANK FOR POTABLE WATER

Determine if there is a check valve, a back flow preventer, a pressure-reducing valve, a water meter or a water softener in the cold water supply line.

A check valve creates a closed system and prevents the water, as it is being heated, from expanding back into the cold water supply line. Pressure can build up within the water heater, causing the relief valve to operate during a heating cycle. This excessive operation can cause premature failure of the relief valve and possibly of the water heater itself.

Replacing the relief valve will not correct the problem. One method of preventing pressure build-up is to install an expansion tank for potable water in the cold water supply line between the heater and check valve. Contact your installing contractor, water supplier, local plumbing inspector or plumbing supply house for assistance.

### RECIRCULATION LINE (IF APPLICABLE)

If a recirculation line is installed, the return connection should be made to a tee close to the inlet connection on the water heater. A check valve should always be installed in the recirculation line to prevent cold water from entering.



# Basic Piping Schematics

This section presents a few basic piping schematics that can be used to pipe a TurboMax with a heat source as well as heat emitters. If additional or more complex schematics are needed, please consult the TurboMax piping schematic catalogue found on the Thermo 2000 website.

## BTH Ultra + TurboMax + two heating zones

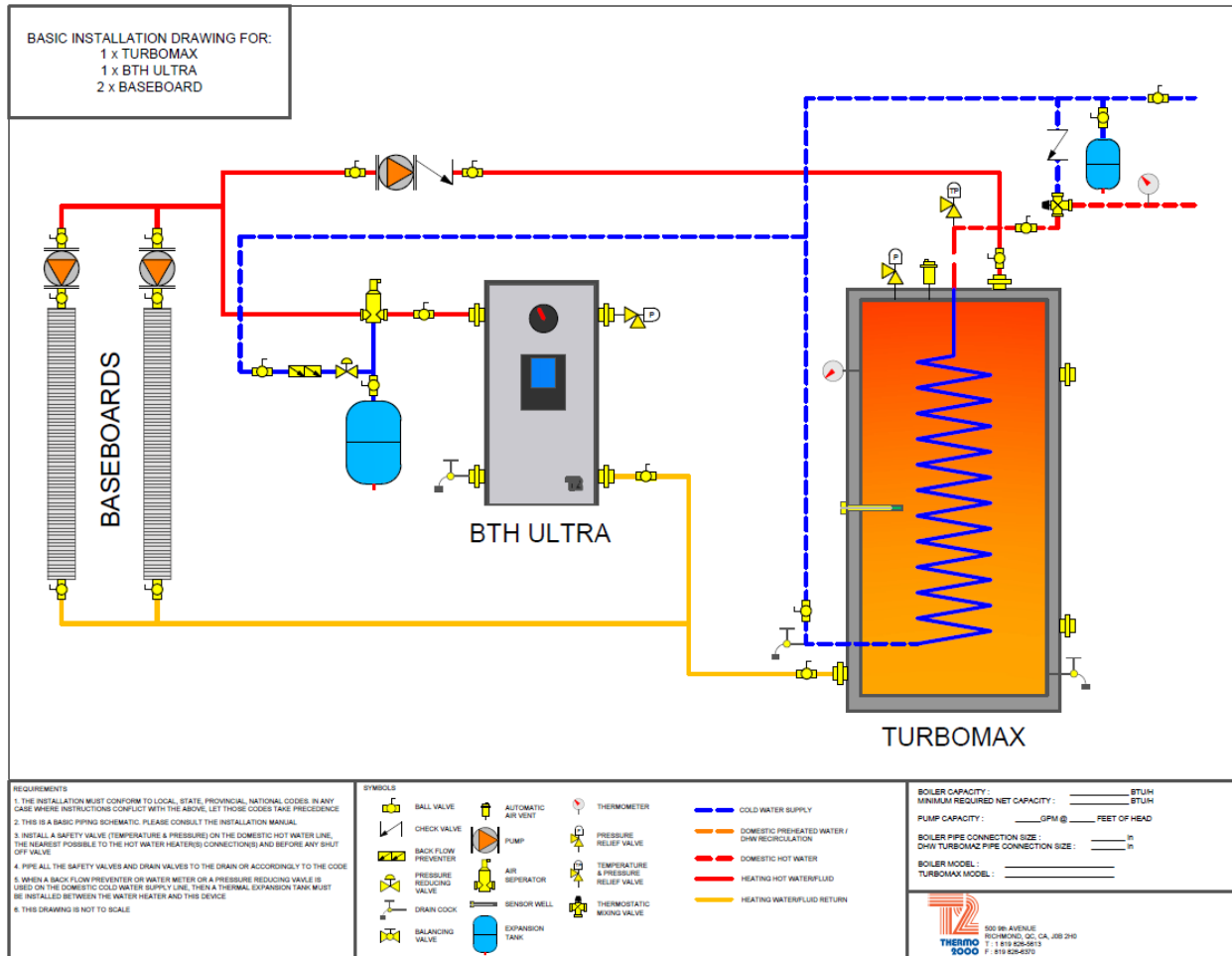

**Requirements:**

1. The installation must conform to local, state, provincial and national codes. In any case where instructions conflict with the above, let those codes take precedence.
2. This is a basic piping schematic and must be adapted to your application.
3. Install a safety valve (temperature & pressure) on the domestic hot water line, as near as possible to the hot water heater connection and before any shut off valve.
4. Pipe all the safety valves and drain valves to the drain or accordingly to the code.
5. When a back flow preventer or water meter or a pressure reducing valve is used on the domestic cold water supply line, then a thermal expansion tank must be installed between the water heater and this device.

## Boiler + TurboMax TXT + 2 zones

The TurboMax comes with two additional connections that enables its use as a buffer tank for your heating circuit as well as supplying the domestic hot water.

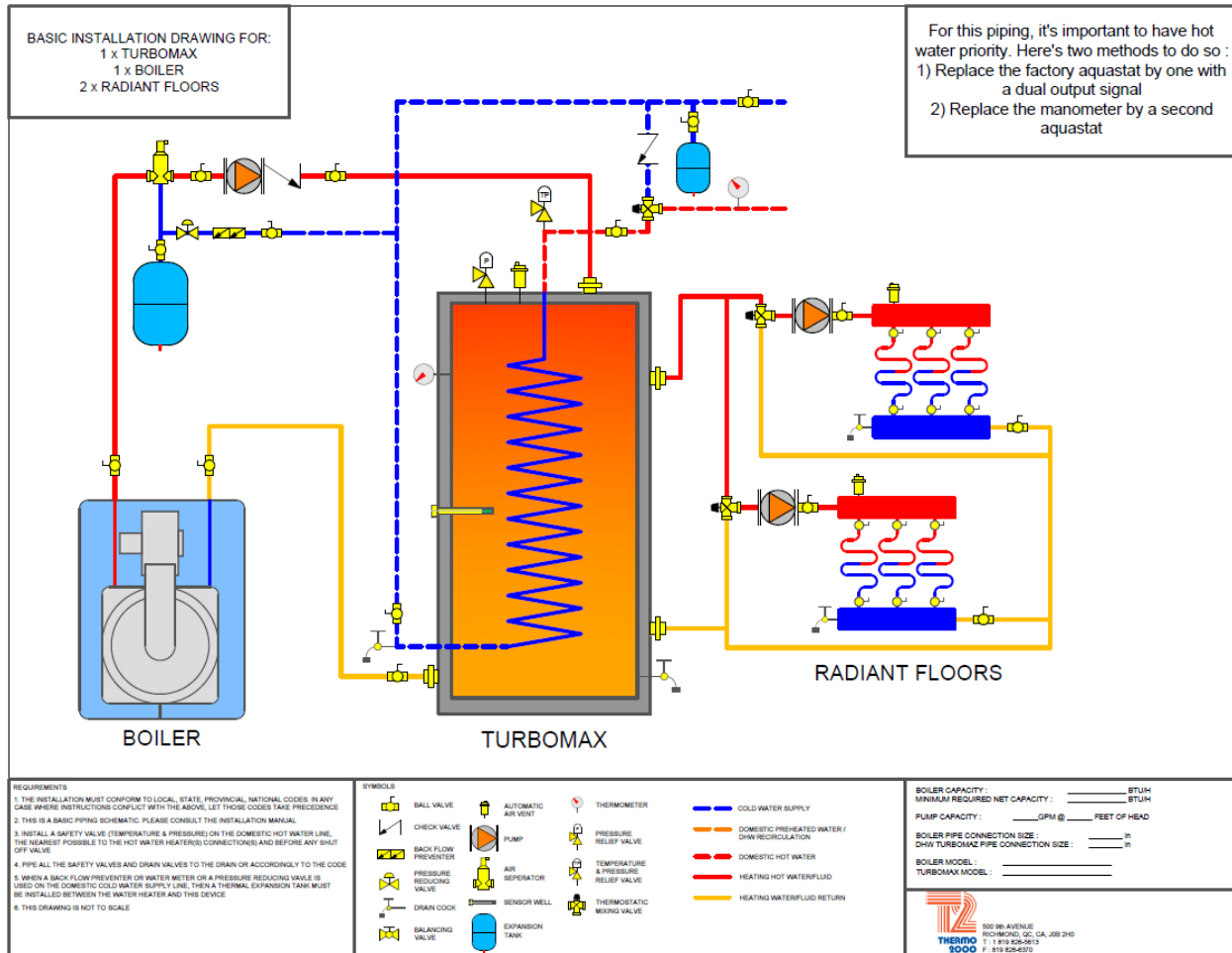

### Requirements:

1. The installation must conform to local, state, provincial and national codes. In any case where instructions conflict with the above, let those codes take precedence.
2. This is a basic piping schematic and must be adapted to your application.
3. Install a safety valve (temperature & pressure) on the domestic hot water line, as near as possible to the hot water heater connection and before any shut off valve.
4. Pipe all the safety valves and drain valves to the drain or accordingly to the code.
5. When a back flow preventer or water meter or a pressure reducing valve is used on the domestic cold water supply line, then a thermal expansion tank must be installed between the water heater and this device.

## TurboMax + Primary/Secondary Boiler piping

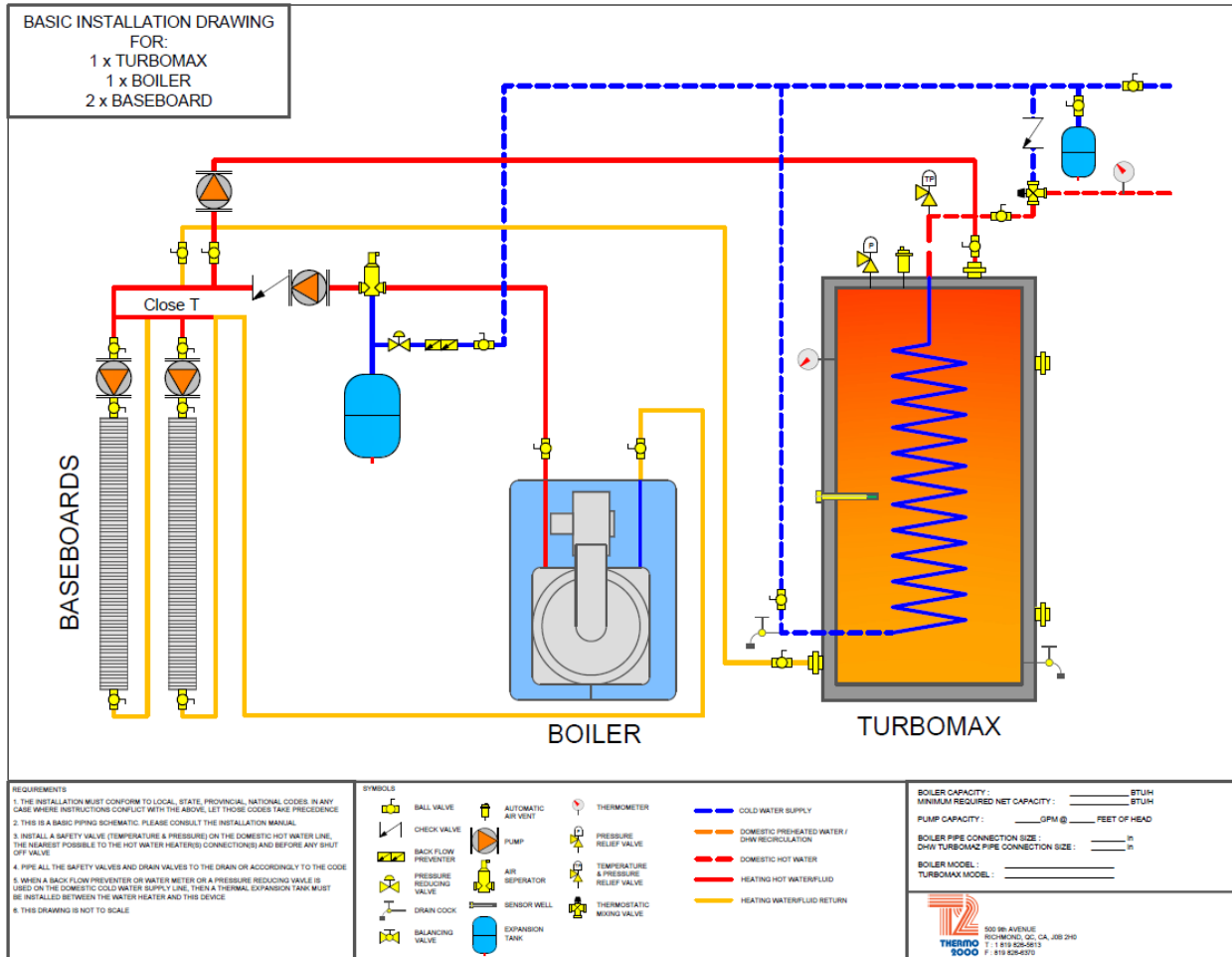

**Requirements:**

1. The installation must conform to local, state, provincial and national codes. In any case where instructions conflict with the above, let those codes take precedence.
2. This is a basic piping schematic and must be adapted to your application.
3. Install a safety valve (temperature & pressure) on the domestic hot water line, as near as possible to the hot water heater connection and before any shut off valve.
4. Pipe all the safety valves and drain valves to the drain or accordingly to the code.
5. When a back flow preventer or water meter or a pressure reducing valve is used on the domestic cold water supply line, then a thermal expansion tank must be installed between the water heater and this device.

## 2 TurboMax with recirculation + 2 Boilers

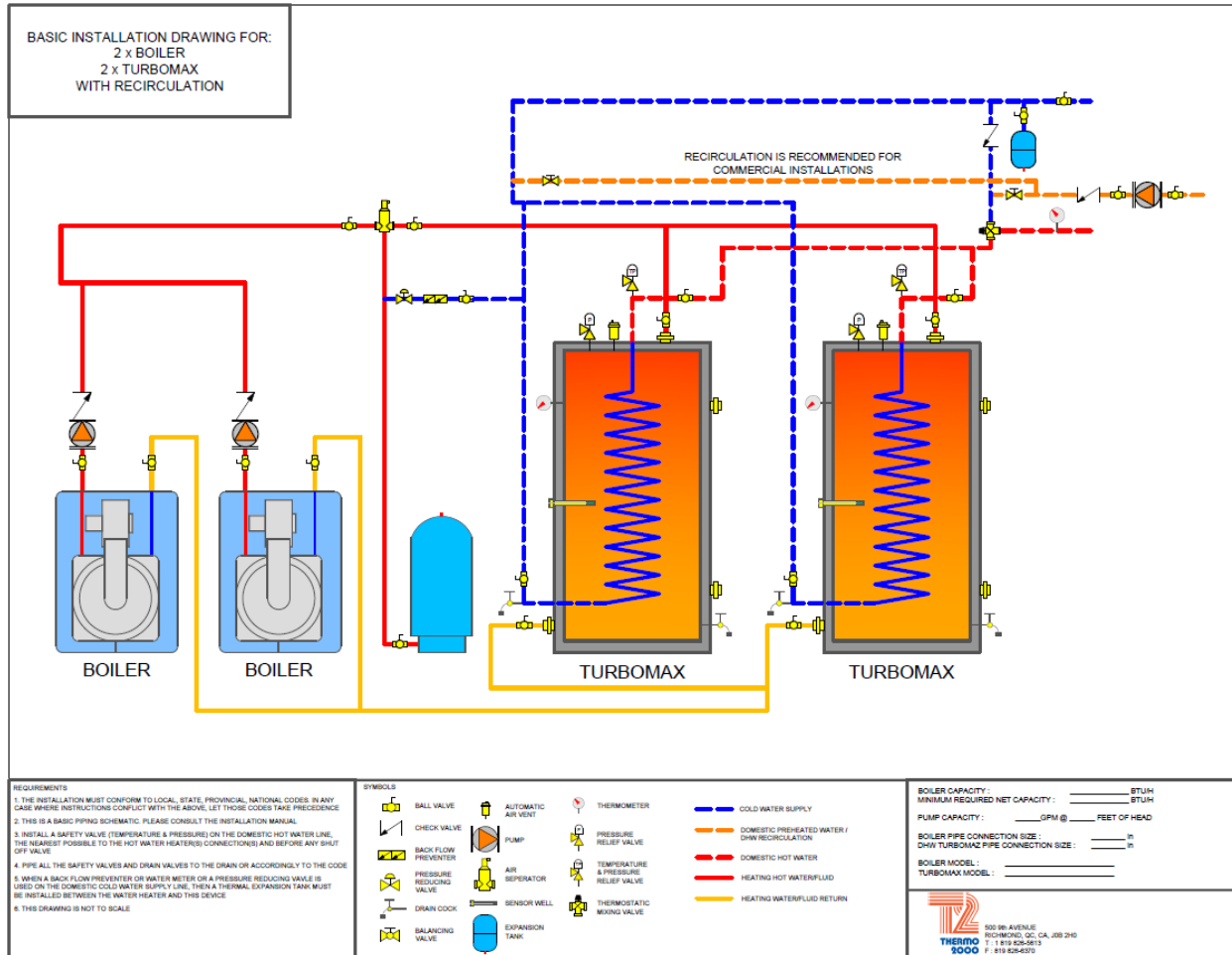

**Requirements:**

1. The installation must conform to local, state, provincial and national codes. In any case where instructions conflict with the above, let those codes take precedence.
2. This is a basic piping schematic and must be adapted to your application.
3. Install a safety valve (temperature & pressure) on the domestic hot water line, as near as possible to the hot water heater connection and before any shut off valve.
4. Pipe all the safety valves and drain valves to the drain or accordingly to the code.
5. When a back flow preventer or water meter or a pressure reducing valve is used on the domestic cold water supply line, then a thermal expansion tank must be installed between the water heater and this device.

## **DOMESTIC HOT WATER TEMPERATURE & PRESSURE RELIEF VALVE**

An automatic temperature & pressure relief valve with a temperature probe of sufficient length must be installed at the time of the installation. No valve of any type should be placed between the T&P relief valve and the water heater. Use a tee to install the relief valve onto the hot water outlet. The pressure rating of the relief valve must not exceed 150 psi.

The BTU per hour rating of the relief valve must equal or exceed the BTU per hour exchange capacity of the TurboMax<sup>®</sup> in the specific operating conditions or the input of the boiler(s) or heat source(s) as marked on the boiler(s) rating plate.

For a circulating tank installation, the separate storage tank(s) must have similar protection.

Connect the outlet of the relief valve to a suitable open drain, so discharge can exit only 6" above the structural floor; and cannot contact any live electrical parts. The discharge line must pitch downward from the valve to allow complete draining (by gravity) of the relief valve and discharge line, and be no smaller than the outlet of the valve. The end of the discharge line should not be threaded or concealed and should be protected from freezing. No valve of any type, restriction or reducer coupling should be installed in the discharge line. Local codes shall govern the installation of relief valves.

## **THERMOSTATIC MIXING VALVE**

When this water heater is supplying general-purpose hot water requirements for use by individuals, a thermostatically controlled mixing valve is recommended to reduce the risk of scald injury. Contact a licensed plumber or the local plumbing authority for further information.

Keep temperature control of the mixing valve at the lowest setting which is satisfactory.

When installing a mixing valve, locate it at the bottom of anti-thermosiphon loop at least 24" high to prevent excessive hot water from entering mixed water supply.

## **VACUUM BREAKER (IF REQUIRED)**

Install a vacuum breaker (or vacuum relief valve) for water heater protection. Prevents siphoning of the water from the system and collapse of the water heater.

## **BOILER WATER CONNECTIONS**

This water heater may be connected individually, in multiples with others, or with an external storage tank containing boiler water. If two TurboMax<sup>®</sup> or more are installed, the piping method to be used to connect the TurboMax<sup>®</sup> in parallel should be "reverse-return piping", so boiler water flow rate through each TurboMax<sup>®</sup> is equal.

The BOILER WATER SUPPLY and BOILER WATER RETURN connections are clearly marked. Boiler water supply connections are to be made to the steel pipe (threaded connection) at the top of the heater. Boiler water return connections are to be made to the steel pipe (threaded connection) at the bottom of the heater.

The installation of unions is recommended on the BOILER WATER SUPPLY and BOILER WATER RETURN lines, so that the water heater may be easily disconnected for servicing if necessary.

Dielectric unions are required for protection of the water heater and the pipes, if dissimilar pipe material like galvanized pipe, copper and steel is used.

Use only clean pipe for boiler water lines. Local codes or regulations shall govern the exact type of material to be used. Install shutoff (ball) valves for servicing convenience. Thermometer(s) should be installed to indicate the temperature of the boiler water supply and return lines.

## **Circulator zoning recommendations**

The preferred location of the circulator pumps for each zone is on the boiler supply, with an expansion tank between the boiler and the circulators.

A flow check valve must be installed on each zone, preferably at the outlet side of each circulator pump, to prevent water flow to other zones when they are not demanding flow.

## **Zone valve zoning recommendations**

The preferred location of the circulator pump is on the boiler supply, with the expansion tank between the boiler and the circulator.

Use zone valves with low pressure drop specifications, particularly on the water heater zone.

## PUMP & PIPE SIZING

### Boiler water temperature drop (TD) through the water heater

Simplified design methods based on a 20°F temperature drop (TD) of boiler water going through the water heater to heat up domestic water are commonly used. Although such methods are widely used and generate satisfactory system performance when applied properly, they do not determine the system operating point. The pipe size is often uneconomically large, and the actual system flow rate is likely to be much higher than intended. Such design methods seldom consider temperature drops higher than 20°F, which results in over-design.

Another method by which the boiler water temperature drop (TD) could be calculated is to assume a constant supply boiler water temperature minus the domestic water final temperature. For example a domestic water heater might have a final temperature of 140 °F. Assuming a constant supply boiler temperature of 180 °F, the TD would be 40 °F (= 180 °F – 140 °F). Second example: If the domestic water heater has a final temperature of 180 °F and the boiler supply is at 200 °F, then temperature drop is 20 °F (= 200 °F – 180 °F).

Precautions should be taken so that the boiler return is above the boiler manufacturer's lowest recommended temperature. Most hot water heating systems use standard, non-condensing boilers (cast iron or steel), which must be operated above 140°F in order to prevent the corrosion that is associated with flue gas condensation.

Alternatively, when the boiler surfaces are hot due to previous loads such as domestic hot water generation, the large temperature difference between the boiler and its return water can cause the boiler to become thermally shocked.

An experienced designer could work with other values than those proposed by looking into the TurboMax® performance tables and use the guidelines stated above to design a state of the art system.

The following chart proposes a temperature drop (TD) that should be used to calculate the pump flow rate.

Proposed boiler water temperature drop through the water heater (TD)		
Boiler water supply temperature	Domestic water final temperature	TD
200 °F	180 °F	20 °F
200 °F	160 °F	40 °F
180 °F	160 °F	20 °F
180 °F	140 °F	20 °F to 40 °F
180 °F	125 °F	20 °F to 40 °F
180 °F	110 °F	20 °F to 40 °F
160 °F	140 °F	20 °F
160 °F	125 °F	20 °F
160 °F	110 °F	20 °F

**NOTE:** The boiler water in TurboMax® constitutes a store of heat energy ready to heat fresh domestic water. The volume of boiler water stored in TurboMax® tank provides enough heat to keep your domestic hot water hot while the boiler heats up. In fact, it acts as a buffer, which prevents domestic hot water, or boiler water temperature swings.

### Pump flow rate calculation

The boiler's output rating must be within the heater's the heat loads calculation or the sizing guide recommendations. Use the equation below to calculate the pump flow rate.

$$\text{Pump flow rate} = \text{Boiler output} \div \text{TD} \div 500$$

- Pump flow rate is express in U.S. gallons per minute or GPM.
- The Boiler output ( in net BTU per hour) is the maximum heat to be transferred through the water heater to meet the hot water demand.
- TD is the boiler water temperature drop through the TurboMax® .

For example, a cast iron boiler has an output rated at 90,000 BTU per hour. The system is designed for a temperature drop (TD) of 20°F.

Pump flow rate =  $90,000 \div 20 \div 500 = 9$  GPM.

### **Pipe sizing criteria**

Proper selection of pipe size is important to efficient system operation. A large pipe size results in lower friction losses and may allow the selection of smaller, more economical pump. The larger pipe, however, costs more initially and must be balanced against the cost savings realized by a smaller pump. Likewise, small pipe costs less initially but must be balanced against the increased operating cost of pumping water through a system with high friction losses. An economical balance should be reached between pump size, operating costs, and pipe diameter.

The ASHRAE fundamentals handbook states the general range of pipe friction loss used for the design of hydronic systems and upper limits of water velocity in piping.

A variety of upper limits of water velocity and/or pressure drop in piping and piping systems are used. One recommendation places a velocity limit of 4 feet per second for 2 inch pipe and smaller, and a pressure drop limit of 4 feet of water per hundred feet for piping over 2 inches. These limitations are imposed either to control the levels of pipe and valve noise, erosion and water hammer pressure or for economic reasons.

Please note that in the smaller pipe sizes, this velocity limit allows the use of friction loss rates higher than 4 feet per 100 feet.

Fluid velocity should be above 1-1/2 to 2 feet per second in order to carry entrained air along with the flowing water to the point of air separation where the air can then be separated from the water and purged.

Velocities greater than 4 feet per second are often used on piping larger than 2 inches.

It is generally accepted that if proper air control is provided to eliminate air and turbulence in the system, the maximum flow rate can be established by the piping friction loss rate at 4 feet of water per 100 feet. This allows the use of velocities higher than 4 feet per second in pipe sized 2 inches and larger.

Tables 1 and 2 provide friction loss values for new pipe. It should be taken into consideration that as the pumping system ages, friction losses increase. It is recommended that for most

commercial design purposes a safety factor of 10 to 15 % be added to the values in the tables.

What is a “foot of water”? A mass of water at 60°F standing inside a vertical column or a vertical pipe 5 feet tall creates a constant pressure of “5 feet of water” at the bottom of the column or pipe. If the water column is 2.31 feet tall, the mass of water creates a constant pressure (head) of one (1) p.s.i. (pound per square inch). Pressure losses are expressed either in “feet of water” or in p.s.i.. Usually, pump manufacturers use feet of water units.

### **Pressure loss from water flow in pipes**

To get the proper boiler water flow through the water heater tank, the pump must overcome the pressure loss from water flow in pipes, valves, fittings and components in the piping circuit. Friction is a resistance to flow.

Pressure loss (or pressure drop) from friction in straight pipe, in Tables 1 and 2, are in feet of water per 100 feet of pipe length.

Example 1: What is the pressure drop caused by water flowing at a rate of 25 GPM (gallons per minute) through a 1-1/2 inch diameter copper tube which has a length of 100 feet?

Answer: by looking at the data in Table 1, you notice that the pressure loss is 5.46 feet of water for a tube of 100 feet.

Example 2: What if the pipe has a length of 40 feet for the same flow rate?

Answer: the pressure loss is 40% (= 40 feet / 100 feet) of 5.46 feet of water per 100 feet. The calculated pressure loss is 2.18 feet of water (= 40% X 5.46 ft water).



### **Pressure loss from water flow in pipe fittings and valves**

In addition to the pressure loss in straight pipe, there will be pressure losses from turbulence and change of direction through fittings and valves. These pressure losses are shown in Table 3.

The pressure losses are expressed in Table 3 in a way that is called the “equivalent length”. The listings for a particular fitting of a given size show the “equivalent length” (E.L.) of straight pipe that would have the same pressure drop.

After finding the “equivalent length” (E.L.) from Table 3, the appropriate friction loss table (Table 1 or Table 2) is used to find the actual pressure drop through the fitting.

Example 3: What is the pressure loss through a 1-1/2 inch 90° copper standard elbow in a piping system through which 25 GPM of water is flowing.

Answer: from Table 3 find the equivalent length of the fitting = 4.5 feet. From Table 1 find the pressure loss for a 1-1/2 inch copper tube, through which 25 GPM of water is flowing = 5.46 feet of water per 100 feet. The pressure loss through the fitting is 4.5% (= 4.5 feet E.L./100 feet) of a straight 1-1/2 inch diameter copper tube. The calculated result is 0.25 feet of water (= 4.5% of 5.46 feet of water)

### **Pressure loss from water flow in TurboMax® tank.**

There will be pressure losses from turbulence and change of direction through TurboMax® tank. These pressure losses are shown in Table 4. The pressure losses through the boiler water’s side (or tank’s side) are expressed in feet of water. The pressure losses, through the domestic water’s side (or copper coil system’s side) are expressed in p.s.i..

Example 4: What is the pressure loss of boiler water flowing through a TurboMax® #120 at 60 GPM? Answer: the pressure loss is 2 feet of water.

### **Pressure loss from boiler or other equipment**

Information on pressure drops (losses) through a boiler or other equipment is obtained from the manufacturer.

### **Piping system pressure drop calculation.**

The pressure loss from friction in a closed piping system is required to determine the required pump head. The system pressure drop is simply the sum of the losses through each item in one circuit from pump discharge to pump suction, including piping, fittings, valves, TurboMax® tank, boiler and other equipment.

To find the system pressure drop, therefore: First inspect the piping layout.

Second, note all the elements through which pressure loss occurs in the circuit from pump discharge to pump suction. Write down the size of the fitting.

Third, measure pipe length and note the pipe diameter and material of the circuit.

Fourth, calculate for each element (pipes, fittings, valves, TurboMax® tank, boiler and other equipment) the pressure loss at the boiler water flow rate calculated earlier.

It should be taken into consideration that, as the piping system ages, friction losses increase. It is recommended that for most commercial design purposes a safety factor of 15 to 20 % be added to the values in Tables 1 and 2.

Fifth, sum all the pressure losses of each item in the circuit

### **Pump or circulator selection**

Consult pump manufacturer’s pump curves to select the proper pump model. Performance characteristics of centrifugal pumps are described by pump curves, which plot flow versus head or pressure together with other information such as efficiency and power.

To select the proper pump that fits your needs, ask your pump dealer or your HVAC wholesaler for a recommendation.

## PIPING SYSTEM PRESSURIZATION

The objective of system pressure control is to limit the pressure on all system equipment to its allowable working pressure, to maintain minimum pressure for all normal operating temperatures, to vent air and prevent cavitation at the pump suction and boiling of system boiler water, and to accomplish these objectives with a minimal addition of new water.

The excess boiler water volume in the system, resulting from increased temperature, is stored in the expansion tank during periods of high operation temperatures and is returned to the system when the system boiler water level is lower.

The expansion tank must be able to store the required volume of boiler water during maximum design operating temperatures without exceeding the maximum allowable operating pressure, and to maintain the required minimum pressure when the system is cold. Contact your installing contractor, plumbing supply house, or local plumbing inspector for assistance.

The point where the expansion tank is connected should be carefully selected to avoid the possibility that normal operation of automatic check or manual valves will isolate the tank from a hot boiler or any part of the system. Pre-charged diaphragm expansion tanks are preferable to air control.

They have a balloon-like bladder (diaphragm or membrane) within the tank that contains air. The bladder does not fill the complete tank and is inflated prior to filling the system to the pressure setting of the makeup water pressure regulator (or fill pressure reducing valve).

The expansion tank should be located at the boiler outlet with the pump located either just upstream or just downstream from the boiler.

Make-up systems must be employed as required by codes. Automatic fill valves must be used with back flow preventors as required, to maintain the minimum system pressure by supplying water to make up for leakage.

The safety relief valve installed on a hot water boiler in accordance with *ASME Boiler and*

*Pressure Vessel Code* limits the maximum pressure on the boiler. Since it is a safety device, it should not be considered an operating control.

Oxygen should be excluded from the system to maintain corrosion-free characteristics, both in pressurization and in the operating cycle. This precludes the use of air in direct contact with the water as a pressurization means.

Installation of manual air vent or automatic air vent devices prevents air accumulation in the system. Air vents should be installed at all high points to remove trapped air during initial operation and to ensure that the system is tight. Check the air vent devices regularly to purge air out of the system. Protect yourself to make sure that the hot boiler water is directed away from all persons or areas where injury or damage could occur.

### Expansion tank sizing

Sizing of the expansion tank depends on the total volume of the system, the maximum and minimum system pressures and temperatures, the piping material, the type of tank, and how it is installed.

To find the expansion tank sizing:  
First inspect the piping layout.

Second, note all the elements through which boiler water circulates from pump discharge to pump suction (i.e. TurboMax<sup>®</sup> tank, boiler(s), storage tank, tubes or pipes)

Third, measure pipes length and note the pipe diameter and material of the circuit.

Fourth, calculate for each element (TurboMax<sup>®</sup> tank, boiler(s), storage tank, tubes or pipes and other equipment) the water content.

Fifth, sum all the water content of each item in the circuit. Used Table 5 to measure the water content of tubes, pipes, TurboMax<sup>®</sup>, storage tank.

Finally size the expansion tank, using Table 6, Table 7. The following data are needed: the total volume of the system, the maximum and minimum system pressures and temperatures, the piping material, the type of tank.

## **WIRING**

Wiring must conform to National Electrical Code and to state or local code requirements having jurisdiction.

The water heater, when installed, must be electrically grounded in accordance with local codes, or, in the absence of local codes, with the National Electrical Code.

All line voltage wiring must be a minimum 18 gauge.

A separate service switch for the water heater electrical circuit is recommended. This switch must not turn off the boiler or other components in the heating system.

All wire connections to “T-T” or “A-A” terminals on the boiler control must be from an insulated circuit, which does not carry voltage from an external source. Any component, which does not have insulated end switches, must not be used unless a relay is added with the dry contacts wires to these terminals.

### **TEMPERATURE CONTROL**

The temperature control of the water heater has the role of closing a contact when the water heater’s temperature drops during domestic hot water consumption. This contact should be connected in such a way that heat from the boiler is supplied to it. This is typically done by activating a dedicated pump and/or by opening a motorized valve. In doing so, a heat demand signal must also be provided to the boiler through a relay or a flow switch.

In application where the TurboMax water heater is paired with a boiler used for both building heating and domestic hot water production, it may be necessary to prioritize the supply of domestic hot water. To achieve this, a control system will be used, which will function to cut off the supply to the pump or heating zone valves during periods of domestic hot water demand. Heating will be reinstated once the domestic hot water demand is met. The two main types of installations combining heating and domestic hot water production are generally found in the two configurations below.

### **Circulator zoning wiring**

Components must be wired to ensure that only the circulator for each zone is powered when demand for supply water occurs in that zone.

An optional multi-zone switching relay is available to simplify the wiring and provide priority to domestic hot water demand.

### **Zone valve zoning wiring**

Components must be wired to ensure that only the zone valve for a particular zone is powered when demand for supply water occurs in this zone, and that the circulator is powered when demand occurs in any zone.

The transformer used to power the zone valves must be sized for the load of all the zones valves in the system.

**WIRING SCHEMATIC : SEPERATE CIRCULATOR 120 VAC, LINE VOLTAGE TO "ZR" TERMINAL OF THE BOILER CONTROL OR TO SUPPLY SIDE OF THE BOILER HI LIMIT CONTROL**

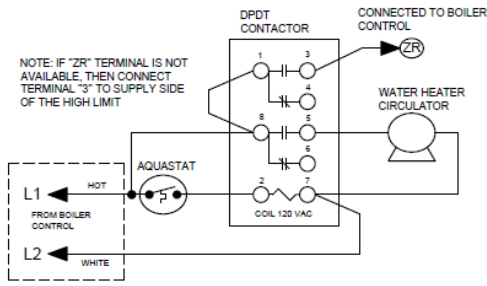

**WIRING SCHEMATIC : SEPERATE CIRCULATOR 24 VAC, DRY CONTACT ON THE BOILER STACK SWITCH "T-T"**

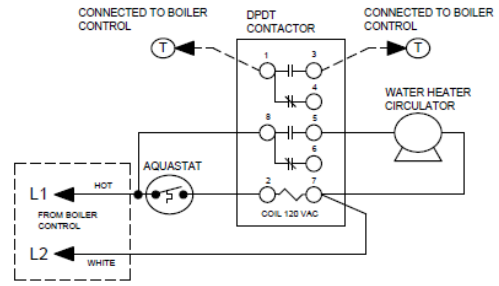

**WIRING SCHEMATIC : PRIORITY TO DOMESTIC HOT WATER**

WATER HEATER HEAT DEMAND ON "T-T" (BOILER CONTROL STACK SWITCH). LINE VOLTAGE TO CIRCULATOR THROUGH BOILER CONTROL "C1-C2"

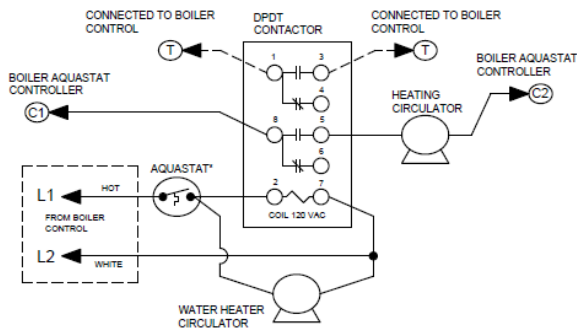

\*CAUTION : The aquastat is limited in operation current. Make sure the pump current rating is adequate for the aquastate current rating. If needed a relay should be used to prevent damage to the aquastat.

**WIRING SCHEMATIC : 3 WIRE ZONE VALVE LOW VOLTAGE - 24 VAC**

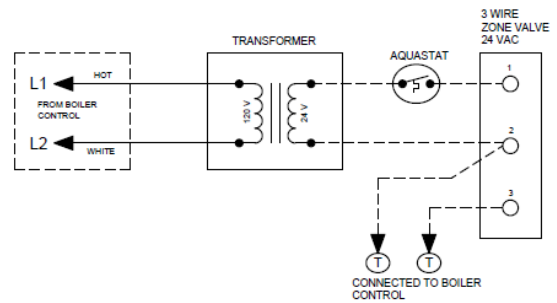

**WIRING SCHEMATIC : 4 WIRE ZONE VALVE LOW VOLTAGE - 24 VAC**

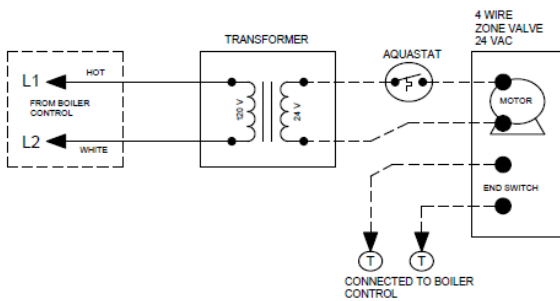

**WIRING SCHEMATIC : 4 WIRE ZONE VALVE LINE VOLTAGE - 120 VAC**

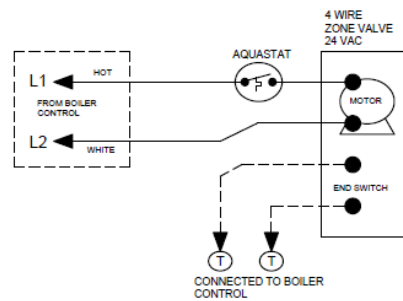

**WIRING : CIRCULATOR ZONING WITH DOMESTIC HOT WATER PRIORITY**

- ⚠ POWER SUPPLY, PROVIDE DISCONNECT MEANS AND OVERLOAD PROTECTION AS REQUIRED.
- ⚠ CONTROL CASE MUST BE CONNECTED TO EARTH GROUND. USE GROUNDING SCREWS PROVIDED.
- ⚠ IF HIGH MASS BOILER, THE BOILER TEMPERATURE MUST BE MAINTAINED CONSTANT BY USING THE BOILER'S OWN TEMPERATURE CONTROLLER.

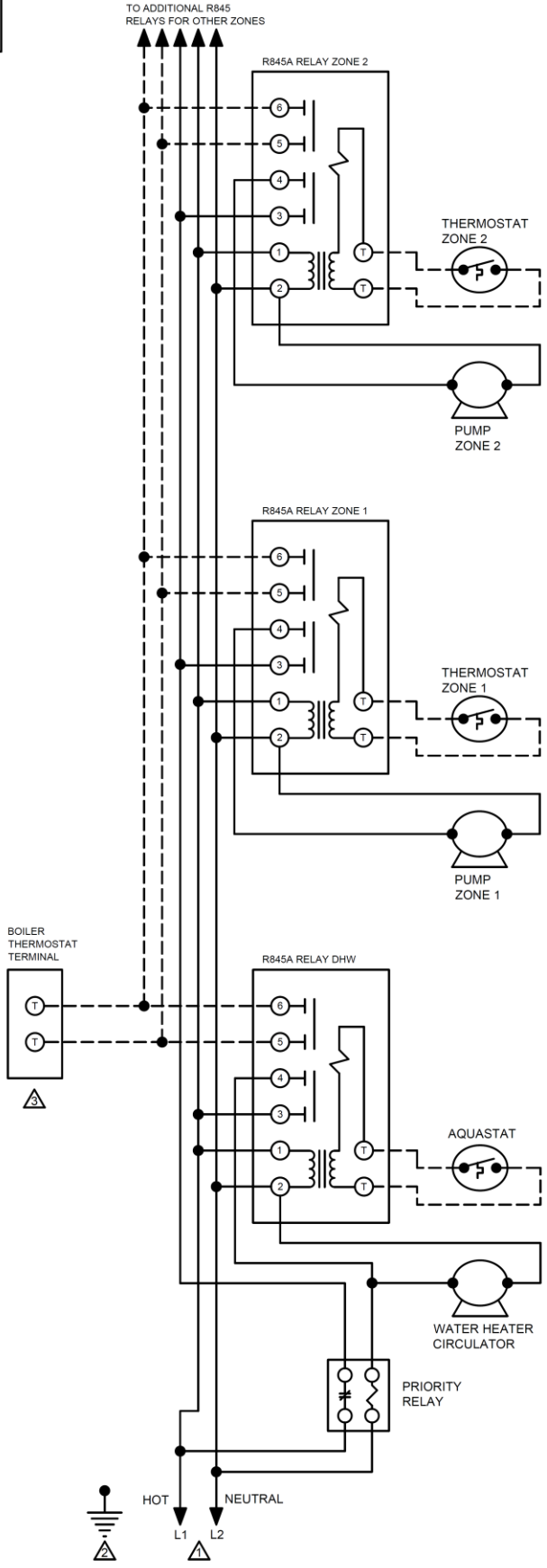

**WIRING : CIRCULATOR ZONING**

⚠️ POWER SUPPLY, PROVIDE DISCONNECT MEANS AND OVERLOAD PROTECTION AS REQUIRED.

⚠️ CONTROL CASE MUST BE CONNECTED TO EARTH GROUND. USE GROUNDING SCREWS PROVIDED.

⚠️ IF HIGH MASS BOILER, THE BOILER TEMPERATURE MUST BE MAINTAINED CONSTANT BY USING THE BOILER'S OWN TEMPERATURE CONTROLLER.

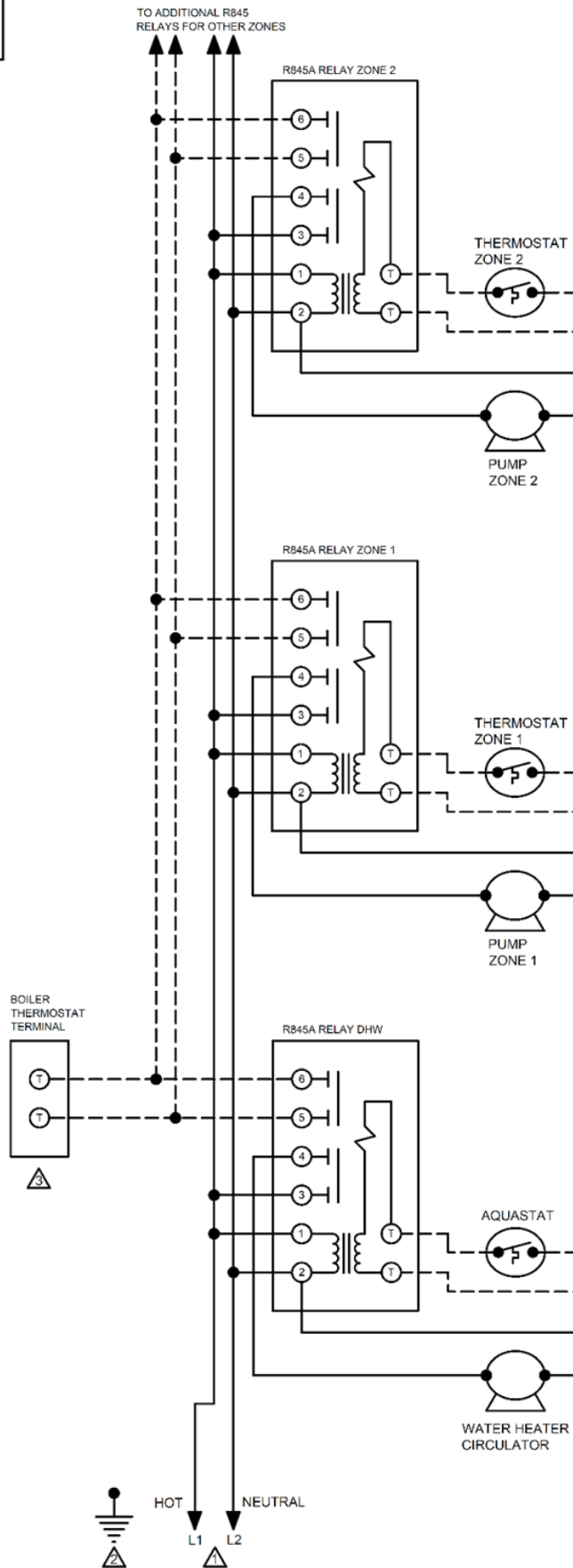

**WIRING : CIRCULATOR ZONING WITH GAS BOILER AND DOMESTIC HOT WATER PRIORITY**

- ⚠ POWER SUPPLY, PROVIDE DISCONNECT MEANS AND OVERLOAD PROTECTION AS REQUIRED.
- ⚠ CONTROL CASE MUST BE CONNECTED TO EARTH GROUND. USE GROUNDING SCREWS PROVIDED.
- ⚠ B1 IS A 1/4 IN. TAB TERMINAL

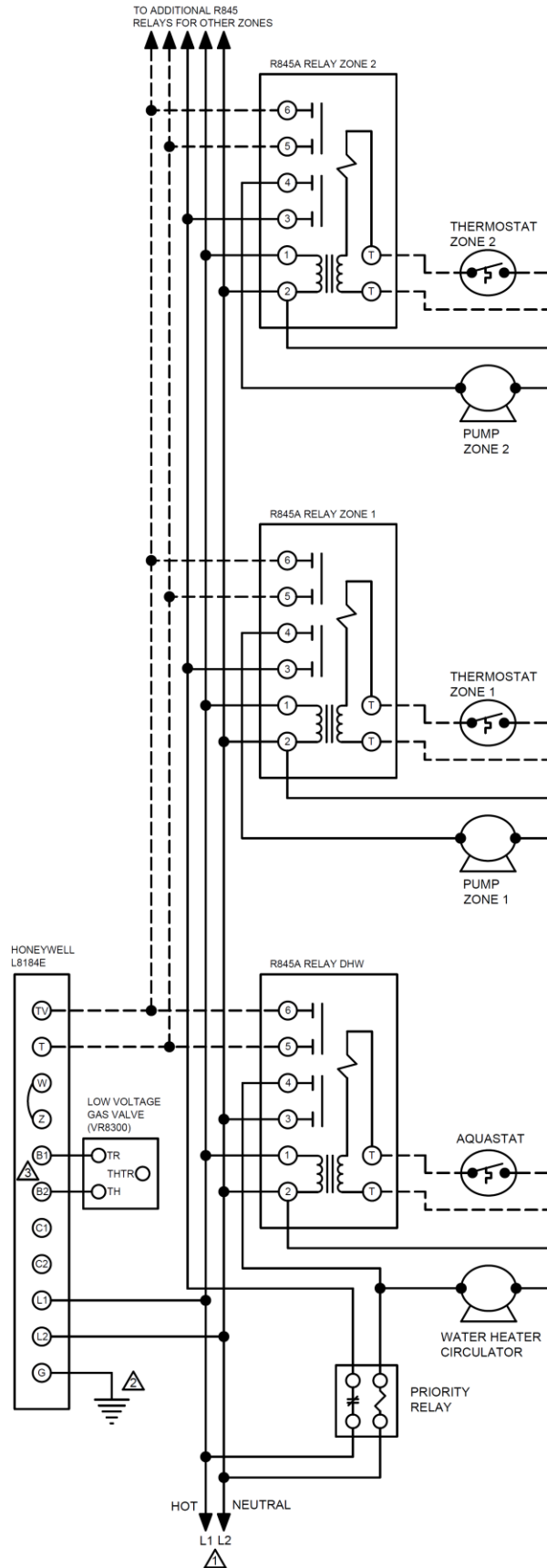



---

## Steam Installation

---

### WARNING

**Do not connect TurboMax® to high-pressure steam boilers. An explosion could occur.**

---

### LOW PRESSURE STEAM BOILER, Piping

Special precautions must be taken when connecting the TurboMax® to a steam boiler. It is recommended that the supply line be connected to the boiler below the water line; see the low water level in the sight glass.

If the supply line is too close to the water level, air or steam may be sucked into the piping system and the TurboMax® tank. Improper piping installation and maintenance will cause the TurboMax® to fail.

If there are no available means of piping below the water line, it is acceptable to pipe the supply line from the bottom of the boiler, but a strainer must be installed in the line; see basic piping schematic. The strainer must be cleaned at regular intervals.

The return line should be piped to the bottom of the boiler and to a section opposite to that from which the supply is taken.

If an accumulation of sludge is expected, hose drains should be installed to permit flushing. Check for any sludge accumulation at regular intervals. The warranty does not cover failure due to sludge accumulation. To prevent sludge accumulation the boiler should be flushed before the water heater unit is installed. Add boiler water conditioner to control acidity level and sludge formation.

Flush the boiler annually at the beginning of each heating season. Boiler water conditioner must be added to the boiler water annually to keep the pH level within the normal EPA (Environmental Protection Agency) recommended range of 6.5 to 8.5 pH level.

The TurboMax® may be installed at a higher level than the water level in the steam boiler. Boiler water in the piping system and in the TurboMax® tank will not flow back into the boiler if all the air

is eliminated from the TurboMax® tank and also from the supply and return lines from the boiler.

Ball valves must be installed on the supply line and on the return line near the boiler to isolate the TurboMax® from the boiler. Also a ball valve should be installed on the boiler supply pipe to let the air out during the fill process. The ball valve outlet must be pipe-to-drain to prevent bodily injury.

To fill the piping system and the TurboMax® tank, close the two isolating ball valves and use hoses connected to the piping drains; see basic piping schematic. To let the air out of the TurboMax® tank during the fill process open the relief valve on top of the TurboMax®. To let the air out of the piping system during the fill process open the ball valve placed on the boiler supply pipe on top of the TurboMax®.

There should be no air vents on the system.

NOTE: Make sure at all time that the tank and piping system are free of trapped air.

### Wiring

When connecting the TurboMax® aquastat to a steam system, it is recommended to wire to the high limit aquastat on the boiler. The high limit aquastat will prevent the boiler from making steam when there is no demand for heating, but will provide adequate hot water to heat the TurboMax®. If the boiler does not have a high limit aquastat, one must be installed and set at 180°F or below to prevent the boiler from making steam when there is no demand for heating, but will provide adequate hot water to heat the TurboMax®.

### DANGER

**There is a Hot Water Scald Potential.**

**When this water heater is supplying general purpose hot water requirements for use by individuals, a thermostatically controlled mixing valve for reducing point of use water temperature is recommended to reduce the risk of scald injury. Contact a licensed plumber or local plumbing authority for further information.**







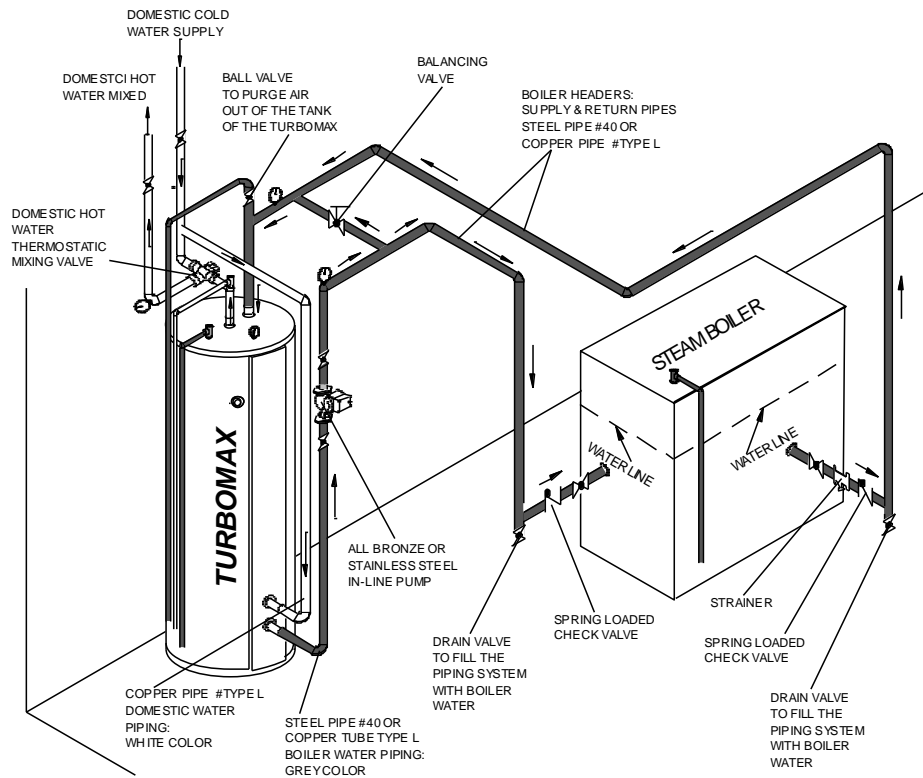





---

# Low Pressure Steam Boiler

## Basic Piping Schematic Using Condensate



### SYMBOLS

 PRIMARY CIRCUIT	 THERMOMETER	 SAFETY VALVE (PRESSURE)
 SECONDARY CIRCUIT	 MANOMETER & THERMOMETER	 SAFETY VALVE (PRESSURE & TEMPERATURE)
 BALL VALVE	 IN-LINE PUMP	 BALANCING VALVE
 FLOW CHECK	 MIXING VALVE	 STRAINER

### Requirements:

1. The installation must conform to local, state, provincial, national codes. In any case where instructions conflict with the above, let those codes take precedence.
2. This is a basic piping schematic. Please consult the installation manual.
3. Install a safety valve (temperature & pressure) on the domestic hot water line as near as possible to the hot water heater connection and before any shut-off valve.
4. Pipe all the safety valves and drain valves to the drain or according to the code.
5. When a back flow preventer or water meter or a pressure reducing valve is used on the domestic cold water supply line, then a thermal expansion tank must be installed between the water heater and this device.

**TURBOMAX WATER HEATERS  
WIRING SCHEMATIC  
LOW PRESSURE STEAM BOILER  
2 OPTIONS**

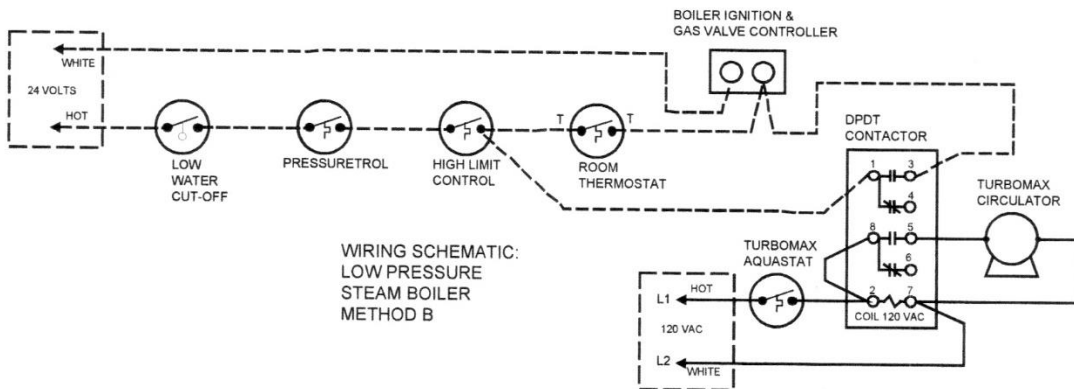
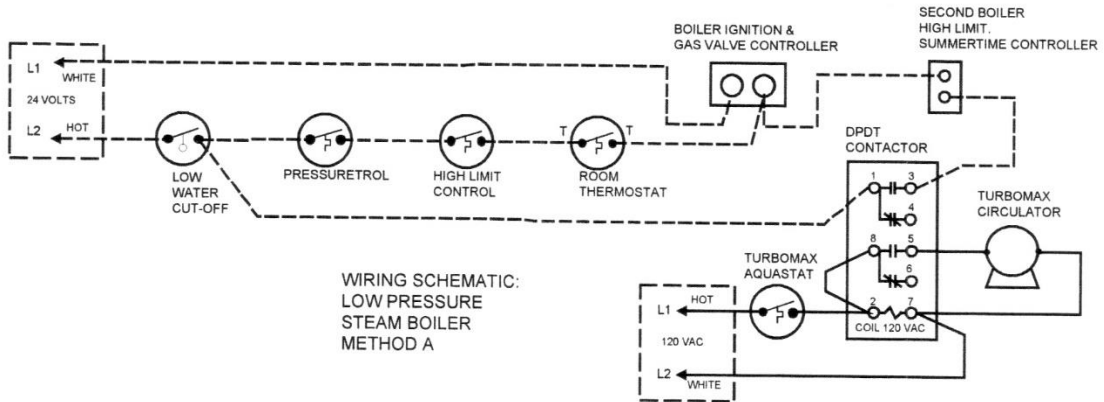

---

## Operation

---

### SAFETY PRECAUTIONS

**Before operating this water heater, be sure to read and follow these instructions, as well as the warnings printed in this manual. Failure to do so can result in unsafe operation of the water heater resulting in property damage, bodily injury, or death. If you have any problems reading, following or difficulty in understanding the instructions in this manual, STOP, and get help from a qualified person.**

**Do not turn on the water heater unless it is filled with water. Do not turn on water heater if cold water supply shut-off valve is closed.**

After the water heater has been plumbed and wired, it is now ready to be set for automatic operation.

### FILLING THE HEATER COILS

Make sure all drains valves on the cold or hot water supply piping are closed.

Open the nearest hot water faucet and any shutoff valves on the domestic hot water supply piping from the heater's domestic hot water outlet (the top copper pipe connection).

Open the shutoff valve on the cold water supply piping to the heater's domestic cold water inlet.

When water discharges from faucet, close it. Check for system leaks and repair if necessary.

Any other water faucets fed by this heater may be opened to purge air from their supply piping, and then shut off after a steady flow of water is observed from the faucet.

### FILLING THE HEATER TANK

Open the shutoff valve (and on a zone valve system, manually open zone valve) on the supply piping from the boiler.

Open cold water supply valve (fill or makeup water valve) to boiler.

To let the air out of the TurboMax<sup>®</sup> tank during the fill process open the relief valve on top of the TurboMax<sup>®</sup>

Leave all shutoff valves open. Return zone valve to automatic operation. Check system for leaks and repair.

Purge air from the remaining zones, if necessary. Check boiler pressure gauge reading afterwards. 15 psi is normal for most installations.

### OPERATING THE WATER HEATER

After the system has been manually purged of its air, and all components (valves, vents, controllers) have been set properly, the boiler can be started. Never operate this heater until this has been done.

Safety and energy conservation are factors to be considered when setting the water temperature on the aquastat. The most energy efficient operation will result when the temperature setting is the lowest that satisfies the needs consistent with the application.

The maximum setting for the boiler water supply to the heater coil is 210°F. The boiler supply temperature should be from 20°F up to 40°F higher than the domestic water temperature. More exactly, the boiler supply temperature should be higher than the domestic supply temperature by more than half the boiler temperature drop (TD) through the TurboMax<sup>®</sup>.

### DANGER

**There is a Hot Water Scald Potential if the aquastat is set too high.**

**When this water heater is supplying general purpose hot water requirements for use by individuals, a thermostatically controlled mixing valve for reducing point of use water temperature is highly recommended to reduce the risk of scald injury.**

**Valves for reducing point-of-use temperature by mixing cold and hot water are also available. Consult a licensed plumber or local plumbing authority for further information.**

When the temperature of the boiler water in the heater is below the setting on the tank control (aquastat), the boiler and circulator should start. If a zone valve is used for this zone, it should open at this time.

When the temperature of the boiler water in the heater tank reaches the temperature setting on the tank control, the boiler and circulator should turn off (and the zone valve, if used, should close). If other zones for heating are creating demand, this would also cause the boiler and circulator(s) to run. Cycling of the boiler on high limit is not abnormal, particularly if only one zone is creating demand.

On initial start-up with a cold tank, a considerable amount of time may be required for the tank to reach desired temperature. Check the temperature at a hot water faucet soon after the burner has completed the first heating cycle. Adjust TurboMax® aquastat as needed.

Note that setting to a lower setting will not have an immediate effect. The stored boiler water will first have to be used. Additional checks of the water temperature should follow completion of a cycle. Further adjustments may be necessary as you use your water heater and space heating system.

The TurboMax® aquastat is adjusted to 180F with a 10F diff. when shipped from the factory. To meet commercial water use needs, it is adjustable up to 220°F. However, water temperature over 125°F can cause severe burns instantly or death from scalds. This is the reason why we recommend the installation of an automatic mixing valve on the distribution system.

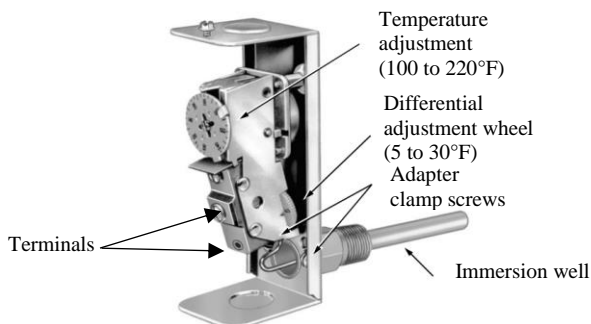

Wire the the common and the open on rise on the terminals. The cutoff happens when the temperature goes above the setpoint. It reactivates when the temperature drops below the setpoint minus the temperature differential.

### Aquastat

Remove the cover by loosening the screw. Adjust the differential dial. Replace the cover and tighten the screw. Using a screwdriver, adjust the temperature dial to align it with the desired temperature in line with the groove.

### OPERATING THE WATER HEATER WITH A THERMOSTATIC MIXING VALVE

A thermostatic mixing valve provides for automatic operation using a thermostatic element inside the valve. The element will control the mixing of the hot and cold water supply streams to provide a safe blend to connected fixtures. This provides constant water temperature under different working conditions.

When using models which are certified ASSE 1017-1998 and, in addition, have successfully passed the cold water supply failure test (ASSE 1016-1996), loss of either hot or cold water to the thermostatic mixing valve will result in a reduction in flow from the valve to less than .5 GPM within seconds of the loss. Pressure difference between Hot and Cold ports should not exceed 10 psi. Valves require a minimum difference of 20°F between the Hot and Mixed temperature for proper operation.

To set the thermostatic mixing valve carefully open a hot water tap. Protect yourself against the risk of scalding. Use a thermometer and measure hot water temperature from the faucet. Reduce or increase the hot water temperature by adjusting the valve knob to the proper position. Lock the knob at the set temperature. Refer to the valve manufacturer's manual to get the proper guidelines.

By mixing domestic cold water to the hot water supplied by the heater, the thermostatic mixing valve allows the boiler to work at higher temperature range. Thus, boiler water stored inside the TurboMax® tank acts as a buffer which increases boiler efficiency and the amount of domestic hot water produced by the heater.

To increase hot water production and storage capacity set the heater aquastat at a higher temperature (from 140°F to 180°F). And secondly set the thermostatic mixing valve at the desired temperature (from 90°F to 120°F). For sanitation purposes use a different temperature range or install a dedicated hot water line to the equipment.

---

## Maintenance

---

Properly maintained, your water heater will provide years of dependable, trouble-free service. It is recommended that a regular routine maintenance program be established and followed by the user. Components, however, may be subject to failure that require service. Failure to use the correct procedures or parts in these circumstances may make the unit unsafe or reduce the life of the heater.

The owner should arrange to have the following inspections and maintenance procedures done:

### Boiler water piping:

- Yearly visual inspection.

Check all piping for signs of leakage at joints, unions and shut-off valves. Remedy as needed.

### Pressure relief valve on top of the water heater:

- Monthly inspection.

Must be manually operated to ensure safe and proper operation. By opening the pressure relief valve, the air trapped inside the heater tank is purged.

Make sure that the discharged water is directed to suitable drain or some collection method, and will not spray onto any person. Use lever on the pressure relief valve to open. A steady discharge of hot water should be noticed. After releasing this lever, the safety relief valve should close and fully shut off this flow. If the pressure relief valve does not function properly, it must be replaced with the same model or its equivalent. Do not plug the outlet of this valve if a dripping condition occurs.

### WARNING

**The manufacturer's warranties DO NOT cover tank failure due to improper installation or maintenance. If the pressure relief valve on the heater discharges periodically, this may be due to thermal expansion. Immediately call a qualified service technician to inspect and to remedy as needed.**

**NOTE: To prevent premature tank failure, the air trapped inside the tank must be purged periodically; use the safety relief valve installed on top of the tank to do so.**

---

### DANGER

**Before manually operating the relief valve, make certain no one will be exposed to the danger of coming in contact with hot water released by safety relief valves. The water may be hot enough to create a SCALD hazard. The water released should be directed to suitable drain to prevent injury or damage**

---

### Domestic water piping:

- Yearly visual inspection.

Check all piping for signs of leakage at joints, unions and shut-off valves. Remedy as needed.

### Temperature & pressure valve:

- Yearly Inspection.

Must be manually operated to ensure safe and proper operation. Make sure that the discharged water is directed to a suitable drain or some collection method, and will not spray onto any person. Use lever on the temperature & pressure valve to open. A steady discharge of hot water should be noticed. After releasing this lever, the safety relief valve should close and fully shut off this flow. If the temperature & pressure valve does not function properly, it must be replaced with the same model or its equivalent. Do not plug the outlet of this valve if a dripping condition occurs.

### Scale:

- Monthly Inspection.

Scale problems occur rarely and under very specific conditions. A domestic water flow rate reduction may indicate scale build-up. A water softener will prevent this problem.

A chemical cleaning process, however, is the most effective process if done properly. If chemical lime dissolving cleaners are preferred, carefully follow the instructions supplied with the cleaner. DO NOT use a muriatic or hydrochloric acid (HCl) based cleaner. Be sure that the manufacturer's directions and warnings on the container are followed. After treatment flush cleaning solution thoroughly. Your plumbing contractor should be contacted to clean the heater of these deposits.

## TROUBLESHOOTING SYSTEM PROBLEMS

SYMPTOM	POSSIBLE CAUSE	ACTION
Insufficient domestic hot water (boiler supplies space heating and hot water needs).	System incapable of prioritizing boiler water for domestic water use.	Install a pump or a valve-zoning panel with the domestic hot water priority feature. When demand occurs for domestic hot water, the zoning panel turns off the space heating system and shunts all its energy into producing DHW.
Insufficiently hot or lack of hot water at the faucet.	TurboMax <sup>®</sup> temperature setting too low.	Set TurboMax <sup>®</sup> temperature control (aquastat) to a higher setting.
	Peak use of hot water is greater than boiler output capacity or TurboMax <sup>®</sup> storage.	Determine peak usage and compare to boiler recovery capacity & tank volume.
	Scale build-up in thermostatic mixing valve or TurboMax <sup>®</sup> .	Clean as described in the Maintenance section.
	Faulty TurboMax <sup>®</sup> temperature control.	Replace temperature controller (aquastat).
No hot water at faucet.	Boiler not operating.	Press reset button. Check main cut-off switch. Check fuse. Call boiler service.
	Circulator not operating.	Check power supply. Check shaft coupling. Check impeller for locking.
	Improper TurboMax <sup>®</sup> setting or calibration.	Set TurboMax <sup>®</sup> temperature to a higher setting. Call boiler service.
	Electrical problems (relays, wiring, fuse, etc).	Check fuses and replace. Check circuit breaker and reset. Check power supply.
	TurboMax <sup>®</sup> scale build-up.	If boiler, circulator and TurboMax <sup>®</sup> temperature controls are operating satisfactory, the coil system may have scale coating. Clean the coil as described in the Maintenance section.
Water at faucet is too hot.	Thermostatic mixing valve temperature setting is too high.	Lower the temperature setting of the mixing valve.
	TurboMax <sup>®</sup> aquastat temperature setting is too high.	Lower the temperature setting of the aquastat or lower the boiler temperature.
	Improper system plumbing.	Compare plumbing to installation guide.
	Improper system wiring.	Compare wiring to installation guide.
Boiler over-cycling during summer or boiler runs for longer periods of time.	Boiler hi-limit set too low.	Increase boiler hi-limit.
	Faulty boiler controller or aquastat.	Replace faulty controller.
	TurboMax <sup>®</sup> scale build-up	Clean the coil as described in the Maintenance section.
Water hammer noise	Use of hot water at high velocity or high flow rate.	Install a water hammer absorber. Reduce water supply pressure. Check water pressure regulator. Use slower closing valves.
	Expansion tank for potable water or heating loop expansion tank problem. Expansion tank locked due to high system pressure.	Check inlet pressure reducing valve setting. Reset if reduced pressure setting is too high. Drain expansion tank and refill with air. If bladder is broken in the expansion tank, replace expansion tank.
	The zone valves have to deal with the high velocity.	Install valves designed to better handle these punishing circumstances.
Water noise in hydronic system.	Air in the hydronic system.	Purge the air from the boiler, the TurboMax <sup>®</sup> and the radiator. If persistent call service.
	Differential pressure across the valve is too high.	Check if the pump or the valves are properly sized.
Water is dripping from the pressure safety relief valve during each boiler cycle.	The expansion tank must be able to store the required volume of boiler water during maximum design operating temperatures without exceeding the maximum allowable operating pressure,	Check expansion tank sizing. Drain expansion tank and refill with air. If bladder is broken in the expansion tank, replace expansion tank.



# Replacement Parts List

## INSTRUCTIONS FOR PLACING A PART ORDER

Address parts orders to the distributor or store where the heater was purchased.

All parts orders should include:

1. Model number and Serial number of the heater
2. Part Description & Part Number as noted below and number of parts desired

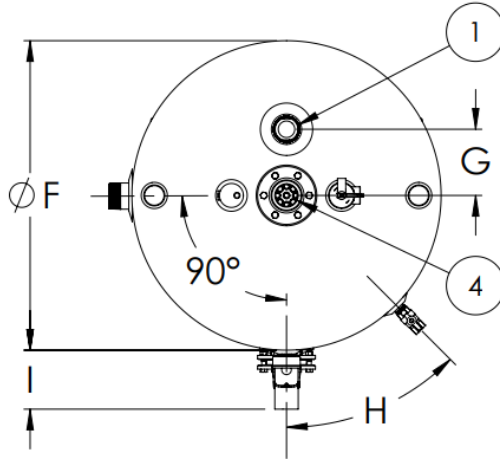
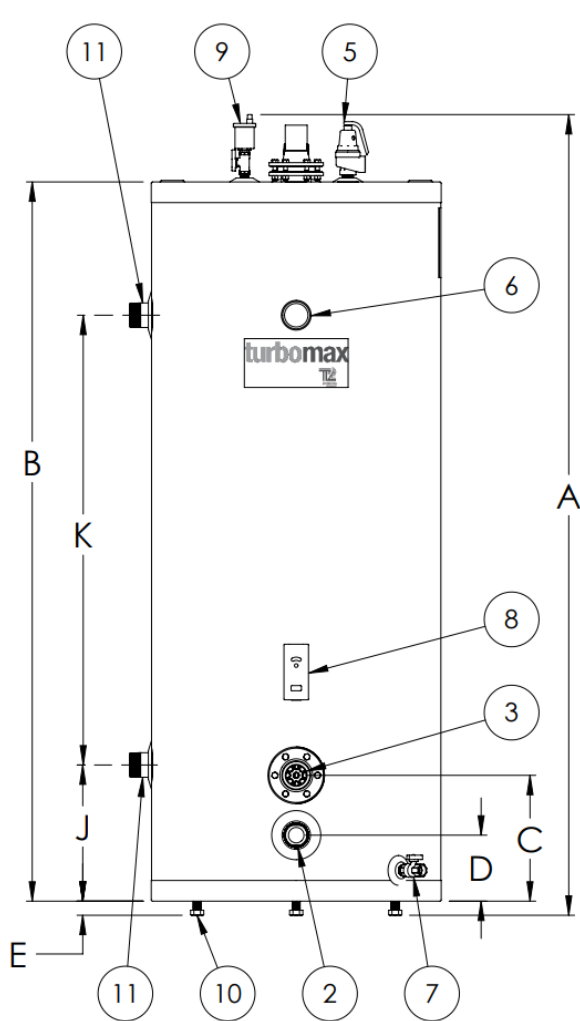

Drawing reference	Description	Part Number	Applicable models
5	30 psi safety valve	ZMC200-SV30PSI2	30, 50, 80
	50 psi safety valve	ZMC200-SV50PSI2	80A
	50 psi safety valve	ZMC200-SV50PSI3	120 et 120A
6	0-75 psi gauge	ZMC300-75P160C2	30-120
	0-200 psi gauge	ZMC300-200P160C	ASME
7	Draining valve	ZMC200-BVP34NPT	All
8	Aquastat	ZEL200-AQAJUSDM	All
9	Air vent	ZMC600-AV1/2	All

**⚠ CAUTION**

**For your safety, DO NOT attempt repair of the aquastat, safety devices or others parts. Refer repairs to qualified service personnel.**

**Table 1: Friction Loss in Feet of Head Per 100 feet of Tube**

<b>COPPER TUBE, TYPE "L" (nominal size in inches)</b>																		
Flow of Water in U.S. GPM	1/2"		3/4"		1"		1-1/4"		1-1/2"		2"		2-1/2"		3"		4"	
	Velocity (Feet/Sec.)	HEAD LOSS (Feet/100 Ft.)	Velocity (Feet/Sec.)	HEAD LOSS (Feet/100 Ft.)	Velocity (Feet/Sec.)	HEAD LOSS (Feet/100 Ft.)	Velocity (Feet/Sec.)	HEAD LOSS (Feet/100 Ft.)	Velocity (Feet/Sec.)	HEAD LOSS (Feet/100 Ft.)	Velocity (Feet/Sec.)	HEAD LOSS (Feet/100 Ft.)	Velocity (Feet/Sec.)	HEAD LOSS (Feet/100 Ft.)	Velocity (Feet/Sec.)	HEAD LOSS (Feet/100 Ft.)	Velocity (Feet/Sec.)	HEAD LOSS (Feet/100 Ft.)
1	1.39	2.47																
2	2.79	8.19	1.31	1.39														
3	4.18	16.65	1.97	2.81	1.17	0.81												
4	5.57	27.63	2.62	4.64	1.56	1.34	1.02	0.50										
5	6.96	40.99	3.28	6.86	1.95	1.98	1.28	0.73										
6	8.35	56.65	3.93	9.46	2.35	2.73	1.54	1.00	1.09	0.44								
7	9.65	74.54	4.59	12.42	2.74	3.58	1.79	1.32	1.27	0.58								
8	11.14	94.59	5.24	15.73	3.13	4.53	2.05	1.66	1.45	0.73								
9			5.90	19.38	3.52	5.57	2.30	2.05	1.63	0.90								
10			6.55	23.37	3.91	6.71	2.56	2.46	1.81	1.08	1.05	0.29						
11			7.21	27.69	4.30	7.95	2.82	2.91	1.99	1.27	1.15	0.34						
12			7.86	32.33	4.69	9.27	3.07	3.40	2.17	1.49	1.26	0.40						
13			8.52	37.30	5.08	10.68	3.33	3.91	2.35	1.71	1.36	0.46						
14			9.17	42.58	5.47	12.19	3.59	4.46	2.54	1.95	1.46	0.52						
15			9.83	48.17	5.86	13.79	3.84	5.04	2.72	2.20	1.57	0.59						
16			10.48	54.08	6.25	15.47	4.10	5.66	2.90	2.47	1.67	0.66						
17					6.64	17.23	4.35	6.30	3.08	2.75	1.78	0.74						
18					7.04	19.08	4.61	6.97	3.26	3.04	1.88	0.82						
19					7.43	21.02	4.87	7.68	3.44	3.35	1.99	0.90						
20					7.82	23.04	5.12	8.41	3.62	3.67	2.09	0.98	1.35	0.35				
25					9.77	34.36	6.40	12.53	4.53	5.46	2.62	1.46	1.69	0.52				
30					11.73	47.69	7.68	17.36	5.43	7.55	3.14	2.02	2.03	0.71	1.42	0.30		
35							8.96	22.89	6.34	9.95	3.66	2.66	2.36	0.94	1.66	0.40		
40							10.24	29.10	7.25	12.64	4.18	3.37	2.70	1.19	1.89	0.51		
45									8.16	15.62	4.71	4.17	3.04	1.46	2.13	0.62		
50									9.06	18.88	5.23	5.03	3.38	1.77	2.37	0.75		
55									9.96	22.41	5.75	5.97	3.71	2.09	2.60	0.89		
60									10.87	26.22	6.28	6.98	4.05	2.45	2.84	1.04		
65											6.80	8.05	4.39	2.39	3.07	1.20		
70											7.32	9.20	4.73	3.22	3.31	1.37		
75											7.85	10.42	5.06	3.65	3.55	1.55		
80											8.37	11.71	5.40	4.10	3.78	1.74		
85											8.89	13.06	5.74	4.57	4.02	1.94		
90											9.41	14.48	6.08	5.06	4.26	2.15		
95											9.94	15.96	6.41	5.58	4.49	2.37		
100											10.46	17.51	6.75	6.12	4.73	2.60	2.68	0.67
110													7.43	7.27	5.20	3.09	2.95	0.79
120													8.10	8.85	5.68	3.61	3.22	0.93
130													8.78	9.82	6.15	4.17	3.49	1.07
140													9.45	11.23	6.62	4.77	3.75	1.22
150													10.13	12.73	7.10	5.40	4.02	1.38
160															7.57	6.07	4.29	1.55
170															8.04	6.77	4.56	1.73
180															8.51	7.51	4.83	1.92
190															8.99	8.28	5.06	2.11
200															9.46	9.09	5.36	2.32
210															9.93	9.93	5.63	2.53
220															10.41	10.80	5.90	2.75
230																	6.17	2.99
240																	6.43	3.22
250																	6.70	3.47
300																	8.04	4.83
350																	9.38	6.39
400																	10.72	8.14

Data for water at 60°F. Note: Friction loss values are for new pipe. It should be taken into consideration that, as the piping system ages, friction losses increase. It is recommended that for most commercial design purposes a safety factor of 15 to 20 % be added to the values in the tables

## Table 2: Friction Loss in Feet of Head Per 100 feet of Pipe

<b>SCHEDULE 40 STEEL PIPE (nominal size in inches)</b>																		
Flow of Water in U.S. GPM	1/2"		3/4"		1"		1-1/4"		1-1/2"		2"		2-1/2"		3"		4"	
	Velocity (Feet/Sec.)	HEAD LOSS (Feet/100 Ft.)	Velocity (Feet/Sec.)	HEAD LOSS (Feet/100 Ft.)	Velocity (Feet/Sec.)	HEAD LOSS (Feet/100 Ft.)	Velocity (Feet/Sec.)	HEAD LOSS (Feet/100 Ft.)	Velocity (Feet/Sec.)	HEAD LOSS (Feet/100 Ft.)	Velocity (Feet/Sec.)	HEAD LOSS (Feet/100 Ft.)	Velocity (Feet/Sec.)	HEAD LOSS (Feet/100 Ft.)	Velocity (Feet/Sec.)	HEAD LOSS (Feet/100 Ft.)	Velocity (Feet/Sec.)	HEAD LOSS (Feet/100 Ft.)
1	1.06	1.39																
2	2.11	4.77	1.20	1.21														
3	3.17	9.98	1.81	2.50	1.11	0.77												
4	4.22	16.97	2.41	4.21	1.49	1.29	0.86	0.34										
5	5.28	25.73	3.01	6.32	1.86	1.93	1.07	0.51										
6	6.34	36.23	3.61	8.85	2.23	2.68	1.29	0.70	0.95	0.33								
7	7.39	48.49	4.22	11.77	2.60	3.55	1.50	0.93	1.10	0.44								
8	8.45	62.48	4.82	15.10	2.97	4.54	1.72	1.18	1.26	0.56								
9	9.50	78.22	5.42	18.82	3.34	5.64	1.93	1.46	1.42	0.69								
10	10.56	95.69	6.02	22.94	3.71	6.85	2.14	1.77	1.58	0.83	0.95	0.25						
11			6.62	27.46	4.08	8.17	2.36	2.10	1.73	0.99	1.05	0.29						
12			7.23	32.38	4.46	9.61	2.57	2.46	1.89	1.16	1.15	0.34						
13			7.83	37.69	4.83	11.16	2.79	2.85	1.34	2.05	1.24	0.39						
14			8.43	43.39	5.20	12.82	3.00	3.27	2.21	1.53	1.34	0.45						
15			9.03	49.49	5.57	14.59	3.22	3.71	2.36	1.73	1.43	0.51						
16			9.63	55.99	5.94	16.48	3.43	4.18	2.52	1.95	1.53	0.57						
17			10.24	62.88	6.31	18.48	3.65	4.68	2.68	2.18	1.62	0.64						
18					6.68	20.58	3.86	5.20	2.84	2.42	1.72	0.71						
19					7.06	22.80	4.07	5.75	2.68	2.99	1.81	0.78						
20					7.43	25.13	4.29	6.33	3.15	2.94	1.91	0.86	1.34	0.36				
25					9.28	38.44	5.36	9.61	3.94	4.45	2.39	1.29	1.67	0.54				
30					11.14	54.51	6.43	13.55	4.73	6.25	2.86	1.80	2.01	0.75	1.30	0.26		
35							7.51	18.15	5.51	8.35	3.34	2.40	2.34	1.00	1.52	0.35		
40							8.58	23.40	6.30	10.74	3.82	3.07	2.68	1.28	1.74	0.44		
45							9.65	29.30	7.09	13.42	4.30	3.83	3.01	1.59	1.95	0.55		
50							10.72	35.86	7.88	16.40	4.77	4.66	3.35	1.93	2.17	0.66		
55									8.67	19.67	5.25	5.58	3.68	2.30	2.39	0.79		
60									9.45	23.23	5.73	6.57	4.02	2.71	2.60	0.93		
65									10.24	27.08	6.21	7.64	4.35	3.15	2.82	1.07		
70											6.68	8.79	4.69	3.62	3.04	1.23		
75											7.16	10.02	5.02	4.11	3.26	1.40		
80											7.64	11.33	5.36	4.65	3.47	1.58		
85											8.12	12.72	5.69	5.21	3.69	1.77		
90											8.59	14.18	6.03	5.80	3.91	1.96		
95											9.07	15.73	6.43	6.36	4.12	2.17		
100											9.55	17.35	6.70	7.08	4.34	2.19	2.52	0.62
110											10.50	20.83	7.37	8.49	4.78	2.86	2.77	0.74
120													8.04	10.01	5.21	3.37	3.02	0.87
130													8.71	11.67	5.64	3.92	3.28	1.01
140													9.38	13.44	6.08	4.51	3.53	1.16
150													10.05	15.35	6.51	5.13	3.78	1.32
160															6.95	5.80	4.03	1.49
170															7.38	6.51	4.28	1.67
180															7.81	7.26	4.54	1.86
190															8.25	8.05	4.79	2.06
200															8.68	8.88	5.04	2.27
210															9.12	9.74	5.29	2.48
220															9.55	10.65	5.54	2.71
230															9.99	11.60	5.80	2.95
240															10.42	12.59	6.05	3.20
250																	6.30	3.45
300																	7.56	4.88
350																	8.82	6.56
400																	10.08	8.47

Data for water at 60°F. Note: Friction loss values are for new pipe. It should be taken into consideration that, as the piping system ages, friction losses increases. It is recommended that for most commercial design purposes a safety factor of 15 to 20 % be added to the values in the tables

**Table 3: Friction Losses Through Pipe Fittings & Valve**

<b>Equivalent Feet of Straight Pipe for Fittings &amp; Valves</b>									
<b>(nominal size in inches)</b>									
<b>Fittings</b>	<b>1/2"</b>	<b>3/4"</b>	<b>1"</b>	<b>1-1/4"</b>	<b>1-1/2"</b>	<b>2"</b>	<b>2-1/2"</b>	<b>3"</b>	<b>4"</b>
90° Elbow standard	1.6 ft	2.3 ft	2.7 ft	3.6 ft	4.5 ft	5.4 ft	6.5 ft	8.5 ft	12.0 ft
90° Elbow medium sweep	1.5 ft	2.0 ft	2.5 ft	3.5 ft	4.0 ft	5.0 ft	6.0 ft	7.0 ft	9.5 ft
90° Elbow long sweep	1.1 ft	1.5 ft	2.0 ft	2.5 ft	2.9 ft	3.6 ft	4.4 ft	5.5 ft	7.2 ft
45° Elbow	0.8 ft	1.0 ft	1.5 ft	1.7 ft	2.0 ft	2.5 ft	3.0 ft	4.0 ft	5.0 ft
Close return bends	5.0 ft	6.0 ft	7.0 ft	9.0 ft	11.0 ft	14.0 ft	16.0 ft	19.0 ft	25.0 ft
Tee - side flow	1.1 ft	1.5 ft	2.0 ft	2.5 ft	2.9 ft	3.6 ft	4.4 ft	5.5 ft	7.2 ft
Tee - straight through	4.0 ft	5.0 ft	6.0 ft	8.0 ft	9.5 ft	13.0 ft	15.0 ft	18.0 ft	23.0 ft
<b>Valves</b>									
Gate valve - open	0.3 ft	0.5 ft	0.6 ft	0.8 ft	0.9 ft	1.2 ft	1.4 ft	1.7 ft	2.4 ft
Gate valve - 1/4 closed	2.1 ft	2.9 ft	3.4 ft	4.8 ft	5.6 ft	7.0 ft	8.4 ft	10.0 ft	14.0 ft
Gate valve - 1/2 closed	12.0 ft	14.0 ft	18.0 ft	24.0 ft	28.0 ft	36.0 ft	41.0 ft	52.0 ft	70.0 ft
Gate valve - 3/4 closed	44.0 ft	59.0 ft	70.0 ft	96.0 ft	116.0 ft	146.0 ft	172.0 ft	213.0 ft	285.0 ft
Globe valve - open	18.0 ft	23.0 ft	29.0 ft	38.0 ft	46.0 ft	58.0 ft	69.0 ft	86.0 ft	116.0 ft
Angle valve - open	9.0 ft	12.0 ft	15.0 ft	20.0 ft	23.0 ft	29.0 ft	35.0 ft	43.0 ft	57.0 ft
Check valve - open	5.0 ft	6.0 ft	7.0 ft	9.0 ft	11.0 ft	15.0 ft	17.0 ft	21.0 ft	27.0 ft
d = smaller diameter	<b>1/2"</b>	<b>3/4"</b>	<b>1"</b>	<b>1-1/4"</b>	<b>1-1/2"</b>	<b>2"</b>	<b>2-1/2"</b>	<b>3"</b>	<b>4"</b>
D = Larger diameter									
<b>Abrupt contraction</b>									
d/D = 1/4	0.8 ft	1.0 ft	1.5 ft	1.7 ft	2.0 ft	2.5 ft	3.0 ft	4.0 ft	5.0 ft
d/D = 1/2	0.6 ft	0.8 ft	1.0 ft	1.4 ft	1.6 ft	2.0 ft	2.5 ft	2.9 ft	4.0 ft
d/D = 3/4	0.4 ft	0.5 ft	0.6 ft	0.8 ft	1.0 ft	1.3 ft	1.5 ft	1.8 ft	2.4 ft
<b>Abrupt enlargement</b>									
d/D = 1/4	1.6 ft	2.3 ft	2.7 ft	3.6 ft	4.5 ft	5.4 ft	6.5 ft	8.0 ft	12.0 ft
d/D = 1/2	1.2 ft	1.4 ft	1.6 ft	2.3 ft	2.7 ft	3.5 ft	4.0 ft	4.8 ft	6.4 ft
d/D = 3/4	0.4 ft	0.5 ft	0.6 ft	0.8 ft	1.0 ft	1.3 ft	1.5 ft	1.8 ft	2.4 ft

**Table 4: Friction Losses Through TurboMax®**

**Pressure Drop VS Boiler Water Flow Rate  
TurboMax® Instantaneous Indirect water heater**

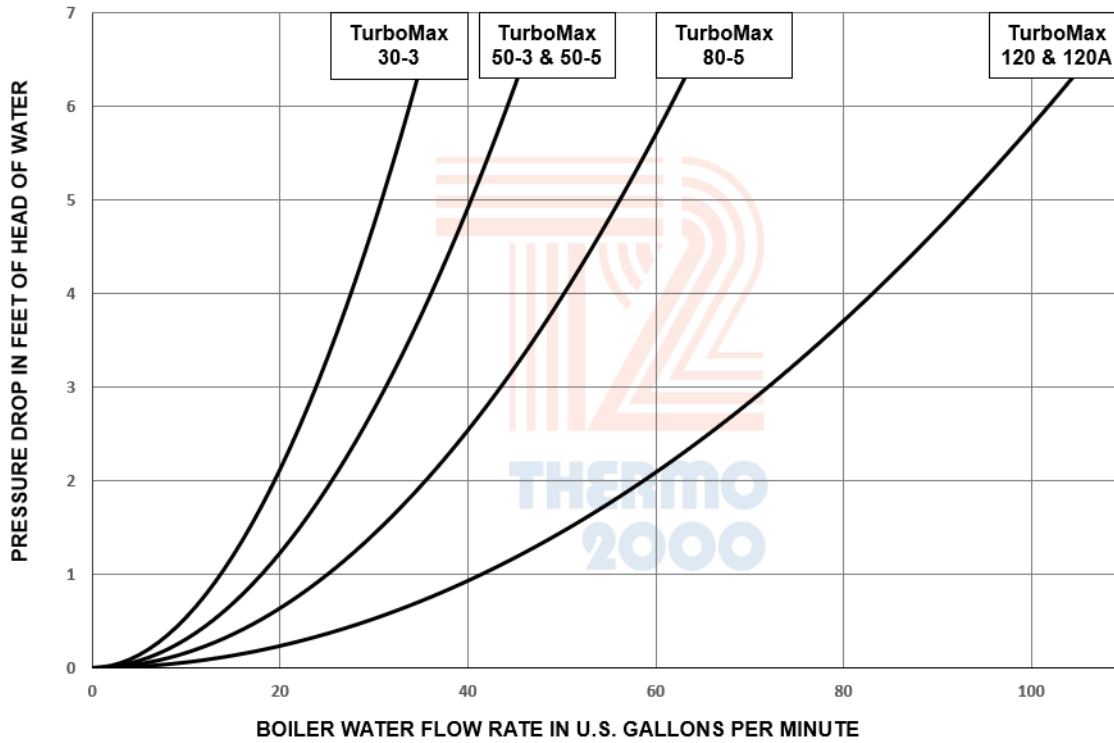

**Domestic Water Side (Secondary Circuit)  
Pressure Drop VS Domestic Hot Water Flow  
TurboMax® Instantaneous Indirect Water Heater**

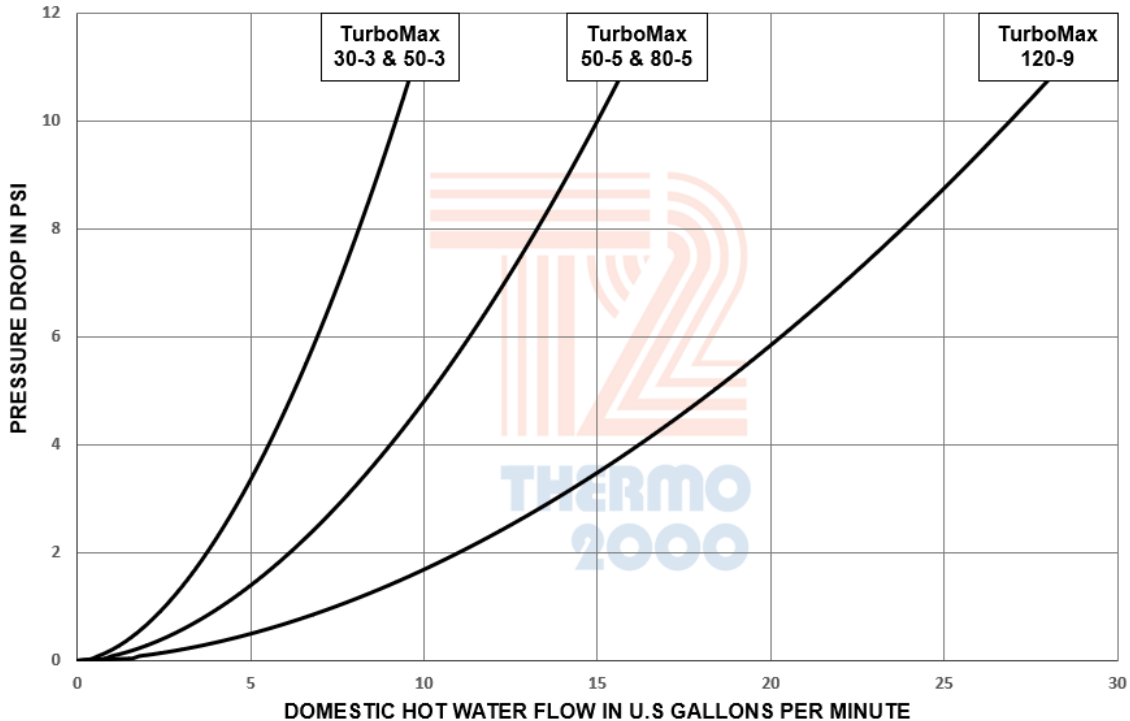

# Spreadsheet 1: Pump sizing. System Flow Rate & Friction Losses Through TurboMax® piping circuit

Step # 1 :

$$\text{Flow rate thru TURBOMAX piping circuit} = \frac{\text{Boiler Net Output (BTU per hour)}}{\text{Temperature Drop (°F)}} \div 500 = \text{System Flow rate (US GPM)}$$

Step # 2 :

Pipe or Tube Description	Pipe or Tube Material	Pipe or Tube Diameter	Flow rate through Pipe or Tube (system flow rate)	Friction Loss in Feet of Head Per 100 feet at system flow rate	Pipe or Tube Length	Friction Losses Total
<input type="text"/>	<input type="text"/>	Inches	US GPM	Feet/100 Feet	X <input type="text"/> Feet	÷ 100 = <input type="text"/> Feet of Head
<input type="text"/>	<input type="text"/>	Inches	US GPM	Feet/100 Feet	X <input type="text"/> Feet	÷ 100 = <input type="text"/> Feet of Head
<input type="text"/>	<input type="text"/>	Inches	US GPM	Feet/100 Feet	X <input type="text"/> Feet	÷ 100 = <input type="text"/> Feet of Head

Step # 3 :

Fittings Item description	Fittings Diameter	System Flow Rate through Fittings	Friction Loss in Feet of Head Per 100 feet at system flow rate	Quantity of Fittings	Fitting Friction Losses Equivalent Feet of Straight Pipe	Friction Losses Total
<input type="text"/>	Inches	US GPM	Feet/100 Feet	X <input type="text"/>	X <input type="text"/> Equivalent Feet	÷ 100 = <input type="text"/> Feet of Head
<input type="text"/>	Inches	US GPM	Feet/100 Feet	X <input type="text"/>	X <input type="text"/> Equivalent Feet	÷ 100 = <input type="text"/> Feet of Head
<input type="text"/>	Inches	US GPM	Feet/100 Feet	X <input type="text"/>	X <input type="text"/> Equivalent Feet	÷ 100 = <input type="text"/> Feet of Head

Step # 4 :

Valves Item description	Valves Diameter	System Flow Rate through Valves	Friction Loss in Feet of Head Per 100 feet at system flow rate	Quantity of Valves	Valves Friction Losses Equivalent Feet of Straight Pipe	Friction Losses Total
<input type="text"/>	Inches	US GPM	Feet/100 Feet	X <input type="text"/>	X <input type="text"/> Equivalent Feet	÷ 100 = <input type="text"/> Feet of Head
<input type="text"/>	Inches	US GPM	Feet/100 Feet	X <input type="text"/>	X <input type="text"/> Equivalent Feet	÷ 100 = <input type="text"/> Feet of Head
<input type="text"/>	Inches	US GPM	Feet/100 Feet	X <input type="text"/>	X <input type="text"/> Equivalent Feet	÷ 100 = <input type="text"/> Feet of Head

Step # 5 :

TURBOMAX description	System Flow rate through circuit	Quantity of TURBOMAX in Parellel	Flow rate through one TURBOMAX	Friction Loss through TURBOMAX at selected flow rate	Friction Losses Total
<input type="text"/>	US GPM	÷ <input type="text"/>	= <input type="text"/> US GPM	Feet of Head	-----copy result to that cell -----> <input type="text"/> Feet of Head

Step # 6 :

BOILER(S) description	System Flow rate through circuit	Quantity of BOILER(S) in Parellel	Flow rate through one BOILER	Friction Loss through BOILER at selected flow rate	Friction Losses Total
<input type="text"/>	US GPM	÷ <input type="text"/>	= <input type="text"/> US GPM	Feet of Head	-----copy result to that cell -----> <input type="text"/> Feet of Head

Step # 7 :

OTHER COMPONENTS description	System Flow rate through circuit	Quantity of COMPONENTS in Parellel	Flow rate through one COMPONENTS	Friction Loss through COMPONENTS at selected flow rate	Friction Losses Total
<input type="text"/>	US GPM	÷ <input type="text"/>	= <input type="text"/> US GPM	Feet of Head	-----copy result to that cell -----> <input type="text"/> Feet of Head
<input type="text"/>	US GPM	÷ <input type="text"/>	= <input type="text"/> US GPM	Feet of Head	-----copy result to that cell -----> <input type="text"/> Feet of Head

Step # 8 :  
PUMP SELECTION

Flow rate	Head Loss	Brand	Model	Connections
<input type="text"/> US GPM	⊗ <input type="text"/> Feet of Head	<input type="text"/>	<input type="text"/>	<input type="text"/>
		Motor H.P.	Motor RPM	Motor Voltage
		<input type="text"/>	<input type="text"/>	<input type="text"/>

## Table 5: Water Content of TurboMax®, Tubes, Pipes and Storage Tank

### TurboMax® Boiler Water Volume

Model	Tank Volume
TurboMax® 120-9A 200 psi	120 US gallons
TurboMax® 120-9A 125 psi	120 US gallons
TurboMax® 120-9	119 US gallons
TurboMax® 80-5A	80 US gallons
TurboMax® 80-5	80 US gallons
TurboMax® 50-5	50 US gallons
TurboMax® 50-3	50 US gallons
TurboMax® 30-3	30 US gallons

### Water content of Copper tube and Steel pipe per 100 linear feet

Pipe Diameter Nominal		Copper tube Type " L "	Steel pipe Sch. 40
inches	mm	Volume in Gallons per 100 feet	Volume Gallons per 100 feet
3/8	10	0.75	
1/2	15	1.21	1.57
5/8	16	1.81	
3/4	20	2.51	2.77
1	25	4.29	4.49
1 1/4	32	6.53	7.79
1 1/2	40	9.24	10.6
2	50	16.1	17.4
2 1/2	65	24.8	24.9
3	80	35.4	38.4
3 1/2	90	47.9	51.4
4	100	62.2	66.1

### Storage Tank Capacity (in US gallons)

		Diameter (in inches)																		
		12	18	24	30	36	42	48	54	60	66	72	78	84	90	96	102	108	114	120
Length (in inches)	24	12	26	47	73	106	144	188	238	294	355	423	496	576	661	752	849	952	1 060	1 175
	30	15	33	59	92	132	180	235	297	367	444	529	621	720	826	940	1 061	1 190	1 326	1 469
	36	18	40	71	110	159	216	282	357	441	533	635	745	864	991	1 128	1 273	1 428	1 591	1 763
	42	21	46	82	129	185	252	329	416	514	622	740	869	1 008	1 157	1 316	1 486	1 666	1 856	2 056
	48	24	53	94	147	212	288	376	476	588	711	846	993	1 152	1 322	1 504	1 698	1 904	2 121	2 350
	54	26	59	106	165	238	324	423	535	661	800	952	1 117	1 295	1 487	1 692	1 910	2 142	2 386	2 644
	60	29	66	118	184	264	360	470	595	734	889	1 058	1 241	1 439	1 652	1 880	2 122	2 379	2 651	2 938
	66	32	73	129	202	291	396	517	654	808	977	1 163	1 365	1 583	1 818	2 068	2 335	2 617	2 916	3 231
	72	35	79	141	220	317	432	564	714	881	1 066	1 269	1 489	1 727	1 983	2 256	2 547	2 855	3 181	3 525
	84	41	93	165	257	370	504	658	833	1 028	1 244	1 481	1 738	2 015	2 313	2 632	2 971	3 331	3 712	4 113
	96	47	106	188	294	423	576	752	952	1 175	1 422	1 692	1 986	2 303	2 644	3 008	3 396	3 807	4 242	4 700
	108	53	119	212	330	476	648	846	1 071	1 322	1 600	1 904	2 234	2 591	2 974	3 384	3 820	4 283	4 772	5 288
	120	59	132	235	367	529	720	940	1 190	1 469	1 777	2 115	2 482	2 879	3 305	3 760	4 245	4 759	5 302	5 875
	132	65	145	259	404	582	792	1 034	1 309	1 616	1 955	2 327	2 730	3 167	3 635	4 136	4 669	5 235	5 833	6 463
	144	71	159	282	441	635	864	1 128	1 428	1 763	2 133	2 538	2 979	3 455	3 966	4 512	5 094	5 711	6 363	7 050
	156	76	172	306	477	687	936	1 222	1 547	1 909	2 310	2 750	3 227	3 742	4 296	4 888	5 518	6 187	6 893	7 638
	168	82	185	329	514	740	1 008	1 316	1 666	2 056	2 488	2 961	3 475	4 030	4 627	5 264	5 943	6 662	7 423	8 225
180	88	198	353	551	793	1 080	1 410	1 785	2 203	2 666	3 173	3 723	4 318	4 957	5 640	6 367	7 138	7 954	8 813	
192	94	212	376	588	846	1 152	1 504	1 904	2 350	2 844	3 384	3 972	4 606	5 288	6 016	6 792	7 614	8 484	9 400	
204	100	225	400	624	899	1 224	1 598	2 023	2 497	3 021	3 596	4 220	4 894	5 618	6 392	7 216	8 090	9 014	9 988	
216	106	238	423	661	952	1 295	1 692	2 142	2 644	3 199	3 807	4 468	5 182	5 949	6 768	7 641	8 566	9 544	10 575	
228	112	251	447	698	1 005	1 367	1 786	2 260	2 791	3 377	4 019	4 716	5 470	6 279	7 144	8 065	9 042	10 074	11 163	
240	118	264	470	734	1 058	1 439	1 880	2 379	2 938	3 554	4 230	4 965	5 758	6 610	7 520	8 490	9 518	10 605	11 750	



## Table 6: Expansion Tank Sizing

Lower system temperature	40 °F	40 °F	40 °F			
Higher system temperature	180 °F	200 °F	220 °F			
Minimum operating pressure at tank	12. psig	15. psig	18. psig			
Maximum operating pressure at tank	30. psig	30. psig	30. psig			
Volume of water in system in US gallons	Volume of Diaphragm Tank (in US gallons)		Volume of Diaphragm Tank (in US gallons)		Volume of Diaphragm Tank (in US gallons)	
	if Copper Piping	if Steel Piping	if Copper Piping	if Steel Piping	if Copper Piping	if Steel Piping
10	0.7	0.7	1.0	1.0	1.6	1.6
20	1.3	1.4	2.0	2.1	3.1	3.2
30	2.0	2.1	3.0	3.1	4.7	4.8
40	2.6	2.8	4.0	4.2	6.2	6.5
50	3.3	3.5	5.0	5.2	7.8	8.1
60	4.0	4.2	6.0	6.3	9.3	9.7
70	4.6	4.8	7.0	7.3	10.9	11.3
80	5.3	5.5	8.0	8.3	12.4	12.9
90	5.9	6.2	9.0	9.4	14.0	14.5
100	6.6	6.9	10.0	10.4	15.5	16.1
120	7.9	8.3	12.0	12.5	18.6	19.4
140	9.2	9.7	14.0	14.6	21.7	22.6
160	10.6	11.1	16.0	16.7	24.8	25.8
180	11.9	12.5	18.0	18.8	28.0	29.0
200	13.2	13.8	20.0	20.8	31.1	32.3
220	14.5	15.2	22.0	22.9	34.2	35.5
240	15.9	16.6	24.0	25.0	37.3	38.7
260	17.2	18.0	26.0	27.1	40.4	41.9
280	18.5	19.4	28.0	29.2	43.5	45.2
300	19.8	20.8	30.0	31.3	46.6	48.4
320	21.1	22.1	32.0	33.3	49.7	51.6
340	22.5	23.5	34.0	35.4	52.8	54.8
360	23.8	24.9	36.0	37.5	55.9	58.1
380	25.1	26.3	38.0	39.6	59.0	61.3
400	26.4	27.7	40.0	41.7	62.1	64.5
420	27.7	29.1	42.0	43.8	65.2	67.8
440	29.1	30.4	43.9	45.8	68.3	71.0
460	30.4	31.8	45.9	47.9	71.4	74.2
480	31.7	33.2	47.9	50.0	74.5	77.4
500	33.0	34.6	49.9	52.1	77.6	80.7
550	36.3	38.0	54.9	57.3	85.4	88.7
600	39.6	41.5	59.9	62.5	93.2	96.8
650	42.9	45.0	64.9	67.7	100.9	104.9
700	46.2	48.4	69.9	72.9	108.7	112.9

<b>Note:</b>	Lower system temperature = At fill conditions
	Higher system temperature = Hi-limit control set point
	Minimum operating pressure at tank = PRV minimum setting
	Maximum operating pressure at tank = Safety relief valve pressure

## Table 7: Expansion Tank Sizing

Lower system temperature	50 °F	50 °F	50 °F
Higher system temperature	180 °F	200 °F	220 °F
Minimum operating pressure at tank	12. psig	15. psig	18. psig
Maximum operating pressure at tank	30. psig	30. psig	30. psig

Volume of water in system in US gallons	Volume of Diaphragm Tank (in US gallons)		Volume of Diaphragm Tank (in US gallons)		Volume of Diaphragm Tank (in US gallons)	
	if Copper Piping	if Steel Piping	if Copper Piping	if Steel Piping	if Copper Piping	if Steel Piping
	10	0.7	0.7	1.0	1.0	1.6
20	1.3	1.4	2.0	2.1	3.1	3.2
30	2.0	2.1	3.0	3.1	4.7	4.9
40	2.7	2.8	4.0	4.2	6.3	6.5
50	3.3	3.5	5.0	5.2	7.8	8.1
60	4.0	4.2	6.0	6.3	9.4	9.7
70	4.7	4.9	7.1	7.3	10.9	11.3
80	5.3	5.6	8.1	8.4	12.5	13.0
90	6.0	6.3	9.1	9.4	14.1	14.6
100	6.7	7.0	10.1	10.5	15.6	16.2
120	8.0	8.4	12.1	12.6	18.8	19.4
140	9.3	9.8	14.1	14.7	21.9	22.7
160	10.7	11.1	16.1	16.8	25.0	25.9
180	12.0	12.5	18.1	18.9	28.1	29.2
200	13.4	13.9	20.1	21.0	31.3	32.4
220	14.7	15.3	22.2	23.0	34.4	35.6
240	16.0	16.7	24.2	25.1	37.5	38.9
260	17.4	18.1	26.2	27.2	40.6	42.1
280	18.7	19.5	28.2	29.3	43.8	45.4
300	20.0	20.9	30.2	31.4	46.9	48.6
320	21.4	22.3	32.2	33.5	50.0	51.9
340	22.7	23.7	34.2	35.6	53.2	55.1
360	24.0	25.1	36.3	37.7	56.3	58.3
380	25.4	26.5	38.3	39.8	59.4	61.6
400	26.7	27.9	40.3	41.9	62.5	64.8
420	28.0	29.3	42.3	44.0	65.7	68.1
440	29.4	30.7	44.3	46.1	68.8	71.3
460	30.7	32.0	46.3	48.2	71.9	74.5
480	32.0	33.4	48.4	50.3	75.0	77.8
500	33.4	34.8	50.4	52.4	78.2	81.0
550	36.7	38.3	55.4	57.6	86.0	89.1
600	40.1	41.8	60.4	62.9	93.8	97.2
650	43.4	45.3	65.5	68.1	101.6	105.3
700	46.7	48.8	70.5	73.3	109.4	113.4

<b>Note:</b>	Lower system temperature = At fill conditions
	Higher system temperature = Hi-limit control set point
	Minimum operating pressure at tank = PRV minimum setting
	Maximum operating pressure at tank = Safety relief valve pressure



# TURBOMAX<sup>®</sup> LIMITED WARRANTY

## **Warranty Coverage for Residential Installation.**

Thermo 2000 Inc. hereby warrants to the original residential purchaser that the TurboMax<sup>®</sup> tank and exchanger (coil assembly) installed in a residential setting shall be free of leaks during normal use and service for a period of fifteen (15) years from the date of purchase as long as the original residential purchaser owns the home in which the unit was originally installed. Residential setting shall mean usage in a single-family dwelling in which the consumer resides on a permanent basis. Also, residential setting shall mean use in multiple family dwellings in which one (1) TurboMax<sup>®</sup> tank and exchanger is to be used in only one (1) dwelling. In the event that a leak should develop and occur within this limited warranty period due to defective material or workmanship, such leak having been verified by an authorized company representative, Thermo 2000 Inc. will repair or replace at our sole option the failed unit with the nearest comparable model at the time of replacement. Additionally in the event of the use of a low pressure steam boiler, Thermo 2000 Inc. warranty to the original residential purchaser of a TurboMax<sup>®</sup> shall apply in the same terms as above, but shall be limited to a period of five (5) years from the date of purchase whether a leak or/and other defects are claimed.

The original residential purchaser is responsible for all costs associated with the removal and reinstallation, shipping and handling to and from manufacturing plant. The replacement unit will be warranted for the remaining portion of time of the original Warranty.

## **Warranty Coverage for Commercial Installation.**

Thermo 2000 Inc. warrants to the original purchaser that the TurboMax<sup>®</sup> tank and exchanger (coil assembly) installed in a commercial setting for ten (10) years.

Commercial setting shall mean use in other than residential setting stated above in the residential setting definition. In the event that a leak should develop and occur within this limited warranty period due to defective material or workmanship, such leak having been verified by an authorized company representative, Thermo 2000 Inc. will repair or replace at our sole option the failed unit with the nearest comparable model at the time of replacement. Additionally in the event of the use of a low pressure steam boiler, Thermo 2000 Inc. warranty to the original purchaser of a TurboMax<sup>®</sup> for commercial installation shall apply in the same terms as above, but shall be limited to a period of five (5) years from the date of purchase whether a leak or/and other defects are claimed.

The original purchaser is responsible for all costs associated with the removal and reinstallation, shipping and handling to and from Manufacturer. The replacement unit will be warranted for the remaining portion of time of the original Warranty.

## **Limited two-year warranty on all TurboMax<sup>®</sup> components & parts**

All other Turbomax<sup>®</sup> components & parts are warranted for a period of two (2) years against defects due to defective material or workmanship. The original purchaser is responsible for all costs associated with the removal and reinstallation, shipping and handling to and from Manufacturer. The components, repaired or replaced are warranted for the residual period of time of the initial warranty on the unit.



### **THERMO 2000 INC.**

500, 9e Avenue, Richmond (Qc) Canada J0B 2H0  
Phone: (819) 826-5613 Fax: (819) 826-6370  
[www.thermo2000.com](http://www.thermo2000.com)

## **Exclusions.**

**Thermo 2000 reserves the right to not apply this warranty, notably for the following points:**

1. Defects or malfunctions resulting from installation, repair, maintenance and/or usage that are not done in conformity with the manufacturer's installation manual; or
2. Defects or malfunctions resulting from installation, maintenance, or repair that are not done in accordance with regulations in force; or
3. Defects or malfunctions resulting from improper installation, maintenance or repair done carelessly or resulting from consumer damage (improper maintenance, misuse, abuse, accident or alteration); or
4. Installation in which a relief valve (pressure) is not installed or if it is not functioning properly, or when it is not connected to a drain to avoid damage to the property; or
5. Installation in which liquid circulating in the tank does not remain in closed circuit or installation in which piping is leaking; or
6. Installation in which the flow rate of liquid circulating in each coil exceeds 3 GPM US; or
7. A polybutylene pipe or radiant panel installation without an oxygen absorption barrier is used; or
8. Installation where the acidity of water is not within the normal Environmental Protection Agency (EPA) (between pH 6.5 – 8.5) guidelines or the domestic water contains abnormal levels of particulate matter or water exceeding 10.5 gpg; or
9. Your home contains any type of water softener system and the unit is not installed and maintained in accordance with the manufacturer specifications; or
10. When installed with a low pressure steam boiler, if sludge is allowed to accumulate in the TurboMax<sup>®</sup> tank and boiler water acidity is lower than pH 6.5 or higher than pH 8.5; or
11. The TurboMax<sup>®</sup> unit is being subject to non-authorized modifications; or
12. Defects or malfunction resulting of storing or handling done elsewhere than Thermo 2000's manufacturing plant; or
13. Units on which the serial number is removed or obliterated.

## **Limitations.**

Thermo 2000 shall not be responsible for any damage, loss, and inconvenience of any nature whatsoever, directly or indirectly, relating to the breakdown or malfunction of the unit. This warranty limits its beneficiary's rights. Nevertheless, the beneficiary may have other rights, which vary from state to state.

This warranty replaces any other expressed or implicit warranty and constitutes the sole obligation of Thermo 2000 towards the consumer. The warranty does not cover cost of removal, reinstallation or shipping to repair or replace the unit, nor administration fees incurred by the original consumer purchaser.

Thermo 2000 reserves its rights to make changes in the details of design, construction, or material, as shall in its judgment constitute an improvement of former practices.

This warranty is valid only for installations made within the territorial limits of Canada and the United States.

This limited warranty is effective as of November 1<sup>st</sup>, 2011.

## **Warranty service procedure**

Only authorized Turbomax<sup>®</sup> dealers are permitted to perform warranty obligations. The owner or its contractor must provide Thermo 2000's head office or authorized depot with defect unit together with the following information: Turbomax model and serial number, copy of the original sales receipt and owner's identification certificate.